



**Board Meeting Agenda  
Thursday, January 16, 2025  
Noon**

**Call to Order**

**Roll Call**

**Approval of Minutes**

**Official Action**

Oath of Office for Phyllis Nichols

Election of 2025 Officers

Resolution 1503 – A Resolution Authorizing and Approving the Disposal of Certain Utility Facilities of the Electric Division of the Knoxville Utilities Board (“KUB”) Located on the University of Tennessee Campus in Knoxville, Tennessee

**President’s Report**

**Other Business and Public Comments**

**Adjournment**

*Note: The Chair may declare a periodic recess in these proceedings as may be necessary for comfort or convenience.*



---

January 9, 2025

Knoxville Utilities Board  
445 S. Gay Street  
Knoxville, Tennessee 37902-1109

Commissioners:

Official action items on the agenda for the January 16 Board meeting include the oath of office for new Commissioner Phyllis Nichols, Board officer elections for 2025, and a resolution authorizing the disposition of certain electric system facilities. An overview of the resolution is provided below.

**Resolution 1503**

The University of Tennessee operates and maintains its own electric power distribution system, providing service to various campus facilities. KUB has certain electric utility facilities (“Electric Facilities”) on the University of Tennessee campus located on Andy Holt Avenue, Melrose Avenue, and Francis Street. The University is seeking to assume ownership of the Electric Facilities and will manage, operate, and maintain the assets as part of its distribution system. Because of the transfer of the Electric Facilities to the University, I have determined the Electric Facilities are no longer necessary for the continued operation of KUB’s electric system or any other system.

Resolution 1503 authorizes and approves the disposition of the Electric Facilities. I recommend its approval on first and final reading.

Respectfully submitted,

A handwritten signature in black ink that reads "Gabriel J. Bolas II". The signature is written in a cursive style.

Gabriel J. Bolas II  
President and CEO

## RESOLUTION NO. 1503

### **A Resolution Authorizing and Approving the Disposal of Certain Utility Facilities of the Electric Division of the Knoxville Utilities Board (“KUB”) Located on the University of Tennessee Campus in Knoxville, Tennessee**

**Whereas**, the Electric Division of KUB has certain electric utility facilities along Andy Holt Avenue, Melrose Avenue, and Francis Street as described on Exhibit A (the “Facilities”) on the University of Tennessee campus (the “University”); and

**Whereas**, the University seeks to assume ownership, management, operation and maintenance of the Facilities, which will allow the University to provide power to these Facilities through the University electric distribution system; and

**Whereas**, because of their transfer to the University, the Facilities are no longer useful and necessary for the continued operation of the Electric System as it now exists, and are not needed for use by any other KUB system; and

**Whereas**, pursuant to Section VII of the KUB Procurement Procedures previously adopted by the KUB Board of Commissioners (the “Board”), the President and Chief Executive Officer (“CEO”) of KUB has determined that the Facilities sought by the University are no longer necessary and useful for the continued operation of the Electric System and are not needed by any other KUB system; and

**Whereas**, the bond resolutions for the KUB Electric Division authorize the disposal of property of the Electric System which the Board determines to be no longer necessary, material to or useful in the operation thereof; and

**Whereas**, in accordance with the City Charter and KUB’s Procurement Procedures and Procurement Guidelines, the sale or disposal of the Facilities sought by the University, may occur in a manner that is in the best interest of KUB and the Electric Division.

**Now, Therefore, Be It Hereby Resolved by the Board of Commissioners of the Knoxville Utilities Board:**

**Section 1.** That the Facilities are no longer necessary, material to or useful in the continued safe, efficient, and economic operation of the KUB Electric System, substantially as it now exists, nor are the Facilities needed by any other KUB system.

**Section 2.** That the President and CEO or the authorized designee of the President and CEO be, and hereby is, authorized and directed to sell or otherwise dispose of the Facilities in a manner that is in the best interest of KUB and the Electric Division, and consistent with KUB's Procurement Procedures and state law, to execute all documents that are necessary and proper to sell, transfer or otherwise dispose of the Facilities and to do all things that the President and CEO or the authorized designee of the President and CEO deems reasonable and necessary to effectuate such sale, transfer or disposal.

**Section 3.** That the proceeds of any sale shall be placed into the accounts of the Electric Division in accordance with the Electric System Bond Resolution.

**Section 4.** That this Resolution shall take effect from and after its passage.

---

Cynthia Gibson, Chair

---

Mark Walker, Board Secretary

APPROVED ON 1<sup>st</sup>  
& FINAL READING: \_\_\_\_\_  
EFFECTIVE DATE: \_\_\_\_\_  
MINUTE BOOK \_\_\_ PAGE \_\_\_\_\_

# EXHIBIT A

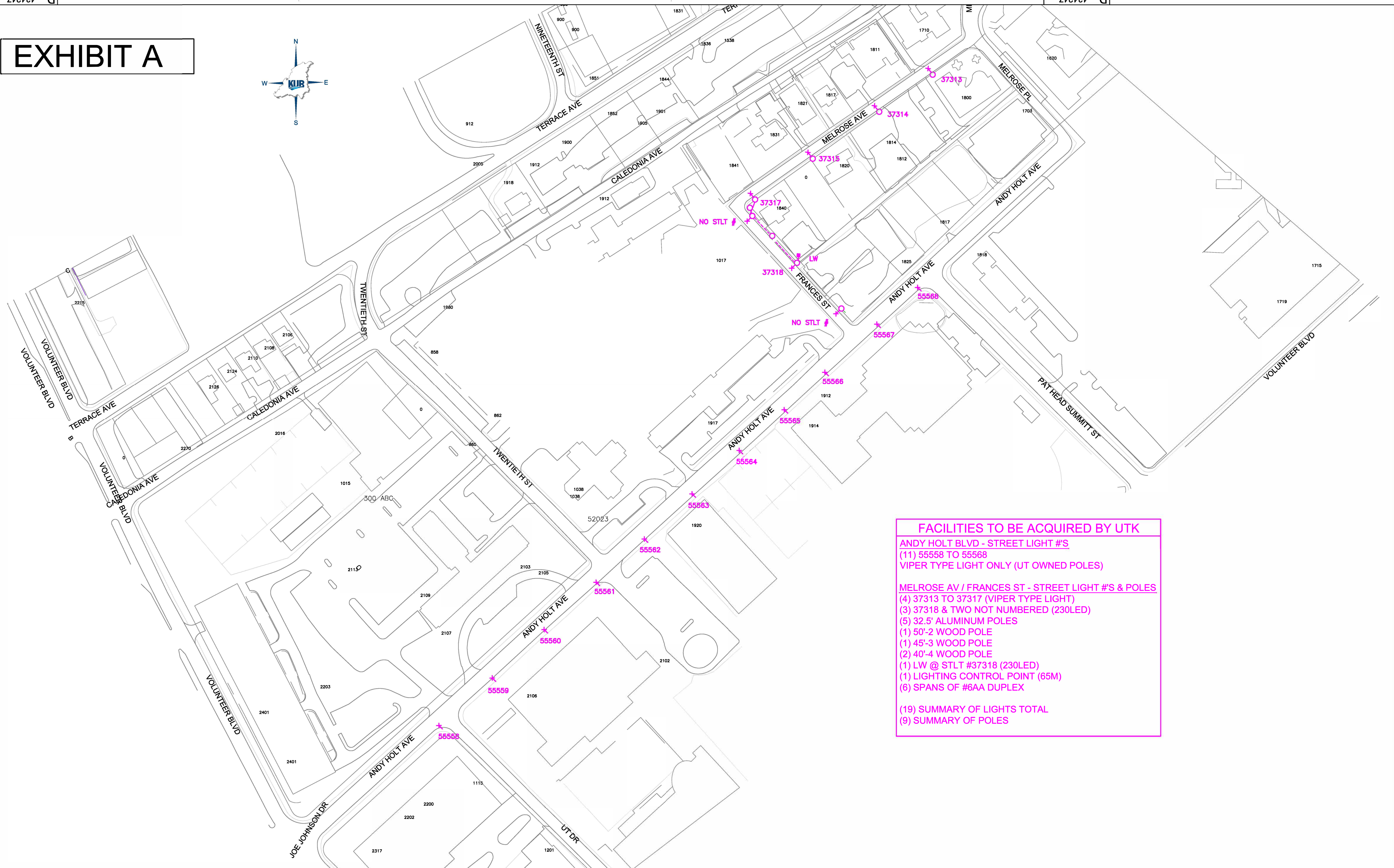

**FACILITIES TO BE ACQUIRED BY UTK**

**ANDY HOLT BLVD - STREET LIGHT #S**  
 (11) 55558 TO 55568  
 VIPER TYPE LIGHT ONLY (UT OWNED POLES)

**MELROSE AV / FRANCES ST - STREET LIGHT #S & POLES**  
 (4) 37313 TO 37317 (VIPER TYPE LIGHT)  
 (3) 37318 & TWO NOT NUMBERED (230LED)  
 (5) 32.5' ALUMINUM POLES  
 (1) 50'-2 WOOD POLE  
 (1) 45'-3 WOOD POLE  
 (2) 40'-4 WOOD POLE  
 (1) LW @ STLT #37318 (230LED)  
 (1) LIGHTING CONTROL POINT (65M)  
 (6) SPANS OF #6AA DUPLEX

(19) SUMMARY OF LIGHTS TOTAL  
 (9) SUMMARY OF POLES

REV	DESCRIPTION	DRAWN BY	CHK.	APPV.	EST#	(INST.)	JOB#	(REM.)	MAXIMO#	W.F.P.#	DATE
6											
5											
4											
3											
2											
1											
0	TRANSFER STREET LIGHT FACILITIES TO UTK	R COCHRAN			434247		J0022986	W24-375156	0510209739	12/12/2024	

**Knoxville Utilities Board  
Board Meeting Minutes  
Thursday, December 19, 2024 Noon**

**Call to Order**

The Knoxville Utilities Board met in regular session in the Larry A. Fleming Board Room at 445 S. Gay Street, on Thursday, December 19, 2024, pursuant to the public notice published in the January 6, 2024, edition of the *News Sentinel*. Chair Adrienne Simpson-Brown called the meeting to order at 12:00 p.m.

**Roll Call**

Commissioners Present: Claudia Caballero, Ron Feinbaum, Cynthia Gibson, Kathy Hamilton, Celeste Herbert, Dr. Craig Pickett, Jr, and Adrienne Simpson-Brown

Commissioners Absent: None

**Approval of Minutes**

Upon a motion by Commissioner Herbert and a second by Commissioner Caballero, the November 21, 2024 Board meeting minutes were approved by a roll call vote. The following Commissioners voted “aye”: Caballero, Feinbaum, Gibson, Hamilton, Herbert, Pickett, Jr, and Simpson-Brown. No Commissioner voted “nay”.

**Old Business**

None

**New Business**

**Resolution 1499, A Resolution Requesting the City Council of the City of Knoxville to Approve the Engagement of Mauldin & Jenkins, LLC, to Provide Audit Services to the Knoxville Utilities Board Beginning with Audits to be Performed in 2025**

Commissioner Hamilton, Chair of the Audit and Finance Committee, advised the Board that the Knoxville City Charter requires the KUB Board to hire an independent accountant to audit KUB financial records. The Charter also requires that the auditor be approved by City Council. At the direction of the Audit and Finance Committee, a request for qualifications (RFQ) was issued earlier this year.

December 19, 2024

Eight firms responded to the RFQ, and their submittals were reviewed by an internal evaluation team. The evaluations were discussed with the Audit and Finance Committee. Based on the evaluations and subsequent pricing information obtained from five firms, the Committee interviewed two finalists.

Following the interview process, the Committee voted unanimously to recommend that, subject to City Council approval, the KUB Board hire Mauldin & Jenkins, LLC to provide audit services to KUB. She recognized Mark Walker, Senior Vice President and Chief Financial Officer, to review the details.

As the adoption of this resolution was recommended by the Audit and Finance Committee, no motion and second were required for this resolution. Resolution 1499 (Attachment 1) was adopted by a roll call vote on first and final reading. The following Commissioners voted “aye”: Caballero, Feinbaum, Gibson, Hamilton, Herbert, Pickett, and Simpson-Brown. No Commissioner voted “nay”.

**Resolution 1500, A Resolution Requesting the City Council of the City of Knoxville to Adopt a Resolution Setting the Tax Equivalent Payments for the Electric, Gas, and Fiber Systems for the Fiscal Year Beginning July 1, 2024, and Providing for the Allocation and Distribution of Such Payments to the Affected Taxing Jurisdictions**

President Gabriel Bolas recognized Chris Hood, Vice President of Finance, who reviewed the proposed tax equivalent payments and distribution of payments for the electric, gas, and fiber systems for fiscal year 2025. He advised that state law requires that City Council adopt a resolution setting the amount of the electric, gas, and fiber payments and providing for their distribution. Mr. Hood also reviewed the water and wastewater systems in lieu of tax payments for fiscal year 2025.

Upon a motion by Commissioner Feinbaum and a second by Commissioner Caballero, Resolution 1500 (*Attachment 2*) was adopted by a roll call vote on first and final reading. The following Commissioners voted “aye”: Caballero, Feinbaum, Gibson, Hamilton, Herbert, Pickett, Jr, and Simpson-Brown. No Commissioner voted “nay”.

**Resolution 1501, A Resolution Authorizing the Execution of Power Purchase Agreements Required to Purchase and Resell Biomass Energy from International Paper Company Under the Tennessee Valley Authority’s Power Supply Expanded Flexibility Program**

December 19, 2024

President Bolas recognized Erin Gill, Vice President of Sustainability and Government Relations, to review the details of power purchase agreements required to purchase biomass energy under TVA's Power Supply Expanded Flexibility Program.

Upon a motion by Commissioner Gibson and a second by Commissioner Herbert, Resolution 1501 (*Attachment 3*) was adopted by a roll call vote on first and final reading. The following Commissioners voted "aye": Caballero, Feinbaum, Gibson, Hamilton, Herbert, Pickett, Jr, and Simpson-Brown. No Commissioner voted "nay".

## **President's Report**

### **Workforce Development Strategic Initiative Update**

President Bolas reminded Commissioners that Workforce Development is one of KUB's Strategic Initiatives this fiscal year. The team has identified strategies to attract, retain, and develop our workforce while continuing to focus on creating an inclusive culture through diversity, equity, and inclusion education and engagement. He recognized Deanna Unger, Director of Human Resources, to provide an update on these initiatives.

### **MBW Filters Project Update**

President Bolas advised Commissioners that work continues on the filters project at the Mark B. Whitaker Water Treatment Plant. This project is a critical component of our Water Supply Master Plan to ensure safe and reliable water service for KUB's customers. He recognized Kurt Stafford, Vice President of Engineering, to provide an update on the project.

## **Other Business**

Commissioner Caballero announced the Nominating Committee met today and voted to nominate the following slate of officers for 2025; Cynthia Gibson, Chair; Claudia Caballero, Vice-Chair; and Mark Walker, Secretary. She also announced that the election of officers would be conducted in January 2025, as required by the Charter.

## **Public Comment**

Cody Smith – Smithbilt Homes



December 19, 2024

**New Business**

**Resolution 1502, A Resolution of the Knoxville Utilities Board Honoring Adrienne Simpson-Brown, who is Concluding Service as a Commissioner**

President Bolas offered Resolution 1502 for the Board’s consideration recognizing Adrienne Simpson-Brown for her service to the KUB Board of Commissioners. Bill Coley, Board’s General Counsel, read Resolution 1502.

Upon a motion by Commissioner Caballero and a second by Commissioner Pickett, Resolution 1502 (*Attachment 4*) was adopted by a roll call vote on first and final reading. The following Commissioners voted “aye”: Caballero, Feinbaum, Gibson, Hamilton, Herbert, and Pickett. No Commissioner voted “nay”.

Commissioner Simpson-Brown thanked the Board and KUB staff and expressed her appreciation for all KUB employees.

**Adjournment**

There being nothing further to come before the Board, Chair Simpson-Brown declared the Board meeting adjourned at 1:12 p.m.

---

Cynthia Gibson, Chair

---

Mark Walker, Board Secretary

Attachment 1	Recommendation Letter and Resolution 1499 – A Resolution Requesting the City Council of the City of Knoxville to Approve the Engagement of Mauldin & Jenkins, LLC, to Provide Audit Services to the Knoxville Utilities Board Beginning with Audits to be Performed in 2025	<b>Page(s)</b> 13265 – 13269
Attachment 2	Resolution 1500 – A Resolution Requesting the City Council of the City of Knoxville to Adopt a Resolution Setting the Tax Equivalent Payments for the Electric, Gas, and Fiber Systems for the Fiscal Year Beginning July 1, 2024, and Providing for the Allocation and Distribution of Such Payments to the Affected Taxing Jurisdictions	13270 – 13275
Attachment 3	Resolution 1501 – A Resolution Authorizing the Execution of Power Purchase Agreements Required to Purchase and Resell Biomass Energy from International Paper Company Under the Tennessee Valley Authority’s Power Supply Expanded Flexibility Program	13276 – 13367
Attachment 4	Resolution 1502 – A Resolution of the Knoxville Utilities Board Honoring Adrienne Simpson-Brown, who is Concluding Service as a Commissioner	13368 – 13369



---

December 13, 2024

Knoxville Utilities Board  
445 S. Gay Street  
Knoxville, Tennessee 37902-1109

Commissioners:

The December 19 Board meeting agenda includes three official action items: approval of an external auditor for financial audits beginning in 2025, approval of electric, gas, and fiber in lieu of tax payments for fiscal year 2025, and authorization to enter into agreements for a renewable generation project under TVA's Power Supply Expanded Flexibility program. An overview of each resolution is provided below.

**Resolution 1499**

The City Charter requires the KUB Board to hire an independent accountant to audit KUB financial records and further requires that the accountant be approved by City Council. In addition, the Board's bylaws state that it is the duty of the Board's Audit and Finance Committee ("Committee") to make recommendations to the Board regarding the selection and engagement of outside auditors.

The recent completion of the FY 2024 audit by Coulter & Justus marked the final year of a total ten-year engagement as KUB's auditor. The Committee previously directed staff to issue a request for qualifications (RFQ) for professional audit services for audits beginning in 2025. Eight firms responded to the RFQ, and the Committee narrowed that list to two finalists who were interviewed by the Committee on December 13. The firms interviewed included Rodefer Moss and Mauldin & Jenkins.

Following the interviews, the Committee voted unanimously to recommend that, subject to City Council approval, the KUB Board hire Mauldin & Jenkins to provide audit services to KUB. Resolution 1499 has been prepared approving the selection of Mauldin & Jenkins and requesting City Council approval of the Board's selection. I recommend adoption of Resolution 1499 on first and final reading.

**Resolution 1500**

State law requires City Council, as the municipality's governing body, to pass a resolution setting the in lieu of tax payments for KUB's electric, gas, and fiber systems each fiscal year and providing for their distribution to the appropriate taxing jurisdictions.

Tax equivalents for the three systems for fiscal year 2025 total \$23,244,154, including \$17,184,661 for the electric system, \$6,044,143 for the gas system, and \$15,350 for the fiber system. The fiber system amount is small given the relatively low value of fiber system assets in place. The electric, gas, and fiber tax equivalent payments are the maximum amounts provided for under state law. These payments will be made to the respective taxing jurisdictions on the last business day of June.

A summary of all tax equivalent payments for fiscal year 2025 is enclosed for your information. Although it doesn't require official action by the Board or City Council, our presentation will also cover the in lieu of tax payments for the water and wastewater systems.

Resolution 1500, enclosed for your information, requests the City Council of Knoxville to set the in lieu of tax payments for KUB's electric, gas, and fiber systems and to establish the allocation of payments to the various taxing jurisdictions for the fiscal year ending June 30, 2025. I recommend its adoption on first and final reading.

### **Resolution 1501**

Staff continues to work through a series of project agreements that will enable KUB to benefit from TVA's Power Supply Expanded Flexibility program, which allows KUB to self-supply 5% of its electric load from certain sources within the Tennessee Valley.

Resolution 1501 authorizes the execution of a series of agreements to purchase up to 32 MW of electricity produced from a renewable biomass facility in Lowndes County, Mississippi (eastern portion of the state). The agreements are designed to be comparatively short-term in nature and allow KUB to benefit financially from the Power Supply Expanded Flexibility program while solar projects, which take several years to build, are under development. Somewhat unique to this arrangement is a scale-down in the contracted capacity, such that the amount of biomass electricity purchased will reduce over time as solar projects come online. This way, the total amount of electricity purchased never exceeds KUB's allocated 5% under the Power Supply Expanded Flexibility program.

The resolution authorizes KUB to execute the following agreements:

- Power Purchase Agreement (PPA) with International Paper Company ("IP") wherein IP agrees to sell, and KUB agrees to purchase, excess electricity produced by the biomass facility, up to a defined maximum amount, at a price equal to 90% of TVA reimbursement (see below).
- Flexibility Option Purchase Power Agreement (FOPPA) with TVA, which runs parallel to the PPA with IP and enables KUB to sell the power to TVA at a defined price of \$49.15 per MWh plus the standard service total monthly fuel cost per MWh produced.

The term of the agreements is 3.5 years, although there is an option to extend up to 5 years, which would be beneficial to KUB in the event other flexibility projects are delayed. The projected average net power cost savings to KUB resulting from the agreements is \$780,000 annually thru June 2028.

Resolution 1501 and the PPA and FOPPA are enclosed for your information. I recommend the approval of Resolution 1501 on first and final reading.

Respectfully submitted,



Gabriel J. Bolas II  
President and CEO

## RESOLUTION NO. 1499

### **A Resolution Requesting the City Council of the City of Knoxville to Approve the Engagement of Mauldin & Jenkins, LLC, to Provide Audit Services to the Knoxville Utilities Board Beginning with Audits to be Performed in 2025**

**Whereas**, the Knoxville City Charter (the “Charter”), Section 1107(B), requires that an independent certified professional accountant shall be employed by the Knoxville Utilities Board of Commissioners (the “Board”) to make such audits and reports as the Board may deem necessary; and

**Whereas**, the Charter further requires that the accountant to be employed shall be approved by the City Council of the City of Knoxville (“City Council”); and

**Whereas**, KUB issued a Request For Qualifications for professional audit services and the Board’s Audit and Finance Committee reviewed the proposals, interviewed finalists, and unanimously adopted Resolution AF-97, recommending the Board adopt a resolution requesting City Council approval of the engagement of Mauldin & Jenkins, LLC, to provide audit services to KUB beginning with audits to be performed in 2025; and

**Whereas**, KUB has prepared a proposed resolution for passage by City Council, a copy of which is attached hereto and made a part hereof (hereinafter referred to as the “Proposed Resolution”).

**Now, Therefore, Be it Hereby Resolved by the Board of Commissioners of the Knoxville Utilities Board:**

**Section 1.** That by adoption of this Resolution, the Board requests that City Council adopt the Proposed Resolution approving the selection of Mauldin & Jenkins, LLC, to provide audit services to KUB beginning with audits to be performed in 2025.

**Section 2.** That subject to the approval of City Council, the Board authorizes the President and CEO or his designee to execute an agreement for the engagement of Mauldin & Jenkins, LLC, to provide audit services to KUB beginning with audits to be performed in 2025.

**Section 3.** That the Board finds that it is in the best interest of KUB and its customers that Mauldin & Jenkins, LLC, be hired to provide audit services to KUB beginning with audits to be performed in 2025.

**Section 4.** That this Resolution shall take effect from and after its passage.

Adrienne Simpson-Brown/s  
Adrienne Simpson-Brown, Chair

Mark Walker/s  
Mark Walker, Board Secretary

APPROVED ON 1<sup>st</sup>  
& FINAL READING: 12-19-24  
EFFECTIVE DATE: 12-19-24  
MINUTE BOOK 49 PAGE 13267-13269

**A Resolution of the Council of the City of Knoxville Approving the Selection Of the Accounting Firm of Mauldin & Jenkins, LLC, to Provide Audit Services to the Knoxville Utilities Board Beginning With Audits to be Performed in 2025, As Required by the Legislative Act Creating the Knoxville Utilities Board**

**Whereas**, the City of Knoxville Charter (the “Charter”), Section 1107(B), requires that an independent certified professional accountant shall be employed by the Knoxville Utilities Board of Commissioners (the “Board”) to make such audits and reports as the Board may deem necessary; and

**Whereas**, the Charter further requires that the accountant to be employed shall be approved by the Council of the City of Knoxville (“City Council”); and

**Whereas**, the Knoxville Utilities Board (“KUB”) issued a Request For Qualifications for professional audit services and the Board’s Audit and Finance Committee reviewed the proposals, interviewed finalists, and unanimously recommended that the Board hire the firm of Mauldin & Jenkins, LLC, to provide audit services to KUB beginning with audits to be performed in 2025; and

**Whereas**, the Board, by adoption of KUB Resolution 1499 finds that it is in the best interest of KUB and its customers that the firm of Mauldin & Jenkins, LLC, be hired to provide audit services to KUB beginning with audits to be performed in 2025 and has requested City Council approval of its selection; and

**Whereas**, it is in the interest of the citizens and residents of the City of Knoxville and KUB’s customers that City Council approve the selection of Mauldin & Jenkins, LLC, to provide audit services to KUB beginning with audits to be performed in 2025.

**Now, Therefore, Be it Hereby Resolved by the Council of the City of Knoxville:**

**Section 1:** That the selection of the accounting firm of Mauldin & Jenkins, LLC, to provide audit services to KUB beginning with audits to be performed in 2025 is hereby approved.

**Section 2:** That this Resolution shall become effective from and after its passage, the welfare of the City requiring it.

---

Mayor

---

City Recorder

## RESOLUTION NO. 1500

### **A Resolution Requesting the City Council of the City of Knoxville to Adopt a Resolution Setting the Tax Equivalent Payments for the Electric, Gas, and Fiber Systems for the Fiscal Year Beginning July 1, 2024, and Providing for the Allocation and Distribution of Such Payments to the Affected Taxing Jurisdictions**

**Whereas**, in accordance with Section 1101 of the Charter of the City of Knoxville, the purchase, sale, and distribution of electric and gas services by the City of Knoxville are under the jurisdiction, control, and management of the Knoxville Utilities Board (“KUB”); and

**Whereas**, the state of Tennessee adopted electric and gas tax equivalent statutes in 1987 (TCA Sections 7-52-301 et seq. and Sections 7-39-401 et seq.) in order to gain uniformity with respect to payments in lieu of taxes on the property and operations of all electric and gas systems owned and operated by incorporated cities or towns, by counties, and by metropolitan governments in the state of Tennessee; and

**Whereas**, the state of Tennessee adopted a tax equivalent statute in 1999 (TCA Section 7-52-606) in order to provide the method for calculation of payments in lieu of taxes on the property and operations of all internet (fiber) or other like systems owned and operated by municipalities in the state of Tennessee; and

**Whereas**, the statutes provide that every municipality may cause an amount to be paid from its electric and/or gas and/or fiber system revenues for tax equivalents which, in the judgment of the municipality’s governing body (i.e. City Council of Knoxville), after consultation with the supervisory body (i.e. KUB), represents the fair share cost of government to be borne by the electric system and/or gas and/or fiber systems; and

**Whereas**, the statutes include formulas which establish the maximum annual tax equivalent payment for electric, gas, and fiber systems; and

**Whereas**, the statutes provide the basis for the allocation and distribution of tax equivalent payments to the various taxing jurisdictions, except to the extent any such payments were allocated and distributed under established arrangements in existence immediately prior to the adoption of the statutes; and

**Whereas**, KUB had an established arrangement for the allocation and distribution of electric and gas system tax equivalent payments, as defined by the statutes, in existence immediately prior to the adoption of said statutes; and



**Whereas**, TCA Section 7-52-606 provides that a municipality providing internet (fiber) services shall make payments in the same manner established for its electric system, except as provided in the statute; and

**Whereas**, KUB has prepared a proposed resolution for passage by the City Council of Knoxville, a copy of which resolution is attached hereto and made a part hereof (hereinafter referred to as the “Proposed Resolution”).

**Now, Therefore, Be It Hereby Resolved by the Board of Commissioners of the Knoxville Utilities Board:**

**Section 1.** That the KUB Board of Commissioners (the “Board”), after due consideration, finds that it is in the best interest of KUB and the City of Knoxville to make electric, gas, and fiber tax equivalent payments for the fiscal year beginning July 1, 2024, totaling \$17,184,661 for the electric system, \$6,044,143 for the gas system and \$15,350 for the fiber system (hereinafter referred to as “Tax Equivalents”), with the aforesaid Tax Equivalents being the maximum amounts permitted by law.

**Section 2.** That this Board, after due consideration, finds that the following allocation and distribution of the aforesaid Tax Equivalents to the following taxing jurisdictions is required under the applicable statutes:

	<u>Electric</u>	<u>Gas</u>	<u>Fiber</u>	<u>Total Tax Equivalents</u>
City of Knoxville	\$9,869,896	\$3,904,990	\$8,920	\$13,783,806
Knox County	6,171,253	2,135,925	6,430	8,313,608
Union County	612,424			612,424
Sevier County	253,737			253,737
Grainger County	180,185			180,185
Jefferson County	79,640			79,640
Blount County	9,288			9,288
Anderson County	8,238	1,719		9,957
Loudon County		<u>1,509</u>		<u>1,509</u>
<b>Total</b>	<b>\$17,184,661</b>	<b>\$6,044,143</b>	<b>\$15,350</b>	<b>\$23,244,154</b>

**Section 3.** That this Board hereby formally requests City Council to pass the Proposed Resolution, and this Board does hereby adopt, ratify, approve, consent and agree to each and every recital and provision contained in the Proposed Resolution.

**Section 4.** That this Board finds that the statutory obligation for consultation with the supervisory body (KUB) will be fulfilled by the delivery of this resolution to City Council.

**Section 5.** That upon City Council's passage of the Proposed Resolution, the President and Chief Executive Officer, or the Chief Financial Officer, is hereby authorized and directed to distribute the Tax Equivalents to the respective taxing jurisdictions in accordance with the Proposed Resolution; provided, however, that the amount of such Tax Equivalents to be paid to any taxing jurisdiction specified in the Proposed Resolution shall be appropriately reduced by the aggregate amount of any qualified state, county, city and other local taxes or charges imposed for such fiscal year by or for the benefit of such taxing jurisdiction, said reduction being required by the statutes.

**Section 6.** That the President and Chief Executive Officer is authorized to deliver copies of this Resolution to the Mayor and City Council as formal evidence of this Board's action in connection therewith.

**Section 7.** That this Resolution shall take effect from and after its passage.

Adrienne Simpson-Brown/s  
Adrienne Simpson-Brown, Chair

Mark Walker/s  
Mark Walker, Board Secretary

APPROVED ON 1<sup>st</sup>  
& FINAL READING: 12-19-24  
EFFECTIVE DATE: 12-19-24  
MINUTE BOOK 49 PAGE 13270-13275

## RESOLUTION

### **A Resolution of the Council of the City of Knoxville Setting the In Lieu of Tax Payments for the Electric, Gas, and Fiber Systems of the Knoxville Utilities Board for the Fiscal Year Beginning July 1, 2024, and Providing for the Allocation and Distribution of Such Payments to the Affected Taxing Jurisdictions**

**Whereas**, under the state of Tennessee electric, gas and internet (fiber) tax equivalent statutes (TCA Section 7-52-301 et seq., Section 7-39-401 et seq. and TCA 7-52-606), the Council of the City of Knoxville, after consultation with the Knoxville Utilities Board (hereinafter referred to as “KUB”), may cause to be paid from KUB’s Electric, Gas, and Fiber Divisions an amount for payments in lieu of taxes (hereinafter referred to as “Tax Equivalents”) on KUB’s electric, gas, and fiber systems and operations which, in the judgment of City Council, shall represent the fair cost of government properly to be borne thereby; and

**Whereas**, the amount of Tax Equivalents on KUB’s electric and gas systems that may be set by City Council is to be in lieu of all state, county, city and other local taxes or charges imposed on KUB’s Electric and Gas Divisions for the fiscal year by the various taxing jurisdictions in which the properties of the electric and gas systems are situated, said amount being subject to a maximum limitation that may be paid for a fiscal year; and

**Whereas**, the amount of Tax Equivalents on KUB’s fiber system that may be set by City Council is to be in lieu of all state, county, city or other local taxes or charges imposed on KUB’s Fiber Division for the fiscal year by the various taxing jurisdictions in which the properties of the fiber system are situated, except as specifically provided in Section 7-52-606; and

**Whereas**, the Tax Equivalents are to be distributed to the respective taxing jurisdictions in accordance with a mandatory distribution formula or under established arrangements with taxing jurisdictions in effect immediately prior to the adoption of the statutes, both as provided for in the statutes; and

**Whereas**, KUB had established arrangements in place with taxing jurisdictions for the allocation and distribution of in lieu of tax payments on KUB’s electric and gas systems immediately prior to the adoption of the statutes; and

**Whereas**, TCA Section 7-52-606 provides that a municipality providing internet (fiber) services shall make payments in the same manner established for its electric system, except as provided in the statute; and

**Whereas**, KUB, by its passage of Resolution No. 1500 on December 19, 2024, and the delivery of same to City Council, has requested City Council pass a resolution setting the Tax Equivalents for the fiscal year beginning July 1, 2024, and providing for the allocation and distribution of the Tax Equivalents to the affected taxing jurisdictions (hereinafter referred to as “Proposed Resolution”); and

**Whereas**, City Council, having consulted with KUB regarding the setting of the Tax Equivalents and the allocation and distribution thereof to the affected taxing jurisdictions, hereby finds that KUB’s Proposed Resolution is in the best interests of the City of Knoxville and KUB.

**NOW THEREFORE BE IT HEREBY RESOLVED BY THE CITY COUNCIL OF THE CITY OF KNOXVILLE:**

**Section 1.** That pursuant to T.C.A. Sections 7-52-301 et seq., Sections 7-39-401 et seq., and Section 7-52-606, the Council of the City of Knoxville hereby sets the Tax Equivalents for KUB’s electric, gas, and fiber systems for the fiscal year beginning July 1, 2024, at a total of \$23,244,154, representing \$17,184,661 in electric Tax Equivalents, \$6,044,143 in gas Tax Equivalents and \$15,350 in fiber Tax Equivalents, said amounts being the maximum amount of Tax Equivalents that may be paid from KUB’s Electric, Gas, and Fiber Divisions under law.

**Section 2.** That the aforesaid Tax Equivalents be distributed in accordance with law to the following taxing jurisdictions in the amounts specified below:

	<u>Electric</u>	<u>Gas</u>	<u>Fiber</u>	<u>Total Tax Equivalents</u>
City of Knoxville	\$9,869,896	\$3,904,990	\$8,920	\$13,783,806
Knox County	6,171,253	2,135,925	6,430	8,313,608
Union County	612,424			612,424
Sevier County	253,737			253,737
Grainger County	180,185			180,185
Jefferson County	79,640			79,640
Blount County	9,288			9,288
Anderson County	8,238	1,719		9,957
Loudon County	<u>                    </u>	<u>1,509</u>	<u>                    </u>	<u>1,509</u>
<b>Total</b>	<b>\$17,184,661</b>	<b>\$6,044,143</b>	<b>\$15,350</b>	<b>\$23,244,154</b>

**Section 3.** That the statutory obligation for City Council to consult with the supervisory body (KUB) was satisfied by the delivery of KUB Resolution No. 1500 to City Council.

**Section 4.** That KUB be and hereby is authorized and directed to aforesaid amounts of Tax Equivalents to the respective taxing jurisdictions specified above; provided, however, that the amount of such Tax Equivalents to be paid to any taxing jurisdiction shall be appropriately reduced by the aggregate amount of any qualified state, county, city and other local taxes or charges imposed for such fiscal year by or for the benefit of such taxing jurisdiction, said reduction being required by law.

**Section 5.** That this resolution shall take effect immediately upon its passage, the public welfare requiring it, and a certified copy hereof shall be delivered to the President and Chief Executive Officer of KUB as formal evidence of this Council's action in connection therewith.

---

Mayor

---

City Recorder

## RESOLUTION NO. 1501

### **A Resolution Authorizing the Execution of Power Purchase Agreements Required to Purchase and Resell Biomass Energy from International Paper Company Under the Tennessee Valley Authority's Power Supply Expanded Flexibility Program**

**Whereas**, pursuant to the TVA Power Contract, TV-75110A, Knoxville Utilities Board ("KUB") has executed a Power Supply Expanded Flexibility Agreement ("Flexibility Agreement") with the Tennessee Valley Authority ("TVA") that gives KUB the flexibility to generate up to 5% of electric energy by deploying certain energy resources, including but not limited to renewable biomass; and

**Whereas**, Tennessee Code § 7-51-910 allows KUB the option to purchase electric power for resale without complying with competitive bidding requirements; and

**Whereas**, under the proposed Power Purchase Agreement ("PPA"), International Paper Company ("IP") will sell to KUB energy output and other associated attributes produced by a biomass electric generation facility; and

**Whereas**, under the proposed Flexibility Option Power Purchase Agreement ("FOPPA"), KUB will sell the purchased power to TVA in exchange for a specified per unit contract price for a term commensurate with the PPA term, up to five years; and

**Whereas**, the pricing terms of the PPA and FOPPA will result in net savings to KUB; and

**Whereas**, the Board has determined, upon recommendation from KUB staff, that it is in the best interest of KUB, its customers, and the community to execute the PPA and FOPPA, respectively.

**Now, Therefore, Be It Hereby Resolved by the Board of Commissioners of the Knoxville Utilities Board:**

**Section 1.** The President and Chief Executive Officer is hereby authorized to execute the PPA with IP, including related documents, substantially in the form attached hereto and is further authorized to approve any minor changes or revisions to said documents as are in the best interest of KUB and its customers.

**Section 2.** The President and Chief Executive Officer is hereby authorized to execute the TVA FOPPA and related documents in substantially the form attached hereto and is further authorized to approve any minor changes or revisions to said documents as are in the best interest of KUB and its customers.

**Section 3.** That this Resolution shall take effect from and after its passage.

Adrienne Simpson-Brown/s  
Adrienne Simpson-Brown, Chair

Mark Walker/s  
Mark Walker, Board Secretary

APPROVED ON 1<sup>st</sup>  
& FINAL READING: 12-19-24  
EFFECTIVE DATE: 12-19-24  
MINUTE BOOK 49 PAGE 13276-13367

**POWER PURCHASE AGREEMENT**

**BETWEEN**

**KNOXVILLE UTILITIES BOARD**

**And**

**INTERNATIONAL PAPER COMPANY**

**DRAFT**



**POWER PURCHASE AGREEMENT**

**BETWEEN**

**KNOXVILLE UTILITIES BOARD**

**AND**

**INTERNATIONAL PAPER COMPANY**

---

THIS AGREEMENT, is made and entered into this \_\_\_ day of \_\_\_\_\_, 2024 (“Effective Date”), by and between KNOXVILLE UTILITIES BOARD, a municipal utility created and existing pursuant to the Charter of the City of Knoxville, Tennessee, hereinafter called “LPC,” and INTERNATIONAL PAPER COMPANY, a New York Corporation, hereinafter called “Seller” or “Operator,” collectively “the Parties,” and each individually a “Party.”

**RECITALS**

WHEREAS, LPC is engaged in the supply of electric power and energy in the Tennessee Valley region;

WHEREAS, Seller owns and operates a biomass electric generation facility known as COLUMBUS CELLULOSE FIBERS COGENERATION FACILITY, located in LOWNDES COUNTY, MISSISSIPPI (the “Project”) with a capacity as measured at the Delivery Point of up to 45 MW, to be interconnected to TVA’s transmission system at TVA’s WEYERHAEUSER 161-kVA SWITCHYARD;

WHEREAS, Seller desires to sell to LPC, and LPC desires to purchase from Seller, Energy Output and Other Project Attributes from the Project, subject to the terms and conditions herein; and

WHEREAS, LPC intends to sell LPC’s Energy Output to TVA pursuant to a separate power purchase agreement between LPC and TVA (“TVA PPA”) in accordance with a TVA program that is commonly known as the “Power Supply Expanded Flexibility Program.”

NOW, THEREFORE, in consideration of the promises and the representations, warranties, covenants, and conditions hereinafter set forth, and for other good and valuable consideration, the receipt and sufficiency of which are hereby acknowledged, the Parties, intending to be legally bound, hereby agree as follows:

**ARTICLE I: DEFINITIONS**

1.1 “Affiliate” means, with respect to any Person, any other Person (other than an individual) that, directly or indirectly, through one or more intermediaries, controls, or is controlled by, or is under common control with, such Person. For this purpose, “control” means the direct or indirect ownership of fifty percent (50%) or more of the outstanding capital stock or other equity interests having ordinary voting power.

1.2 “Ancillary Services” means those services that are necessary to support the transmission of capacity and energy from resources to loads while maintaining reliable operation of TVA’s transmission system in accordance with Good Utility Practice. For the avoidance of doubt, Ancillary Services do not include continuous reactive power support that Seller may provide to TVA pursuant to the terms of a separate agreement.

1.3 “Applicable Law” means all Federal, state, local, or municipal laws, statutes, codes, acts, treaties, ordinances, orders, judgments, writs, decrees, injunctions, rules, regulations, governmental

approvals, licenses, permits, directives, and requirements of all regulatory, judicial, and other Governmental Authorities that legally apply in the particular situation in question.

1.4 “Bankrupt” means with respect to any Person, such Person (i) files a petition or otherwise commences, authorizes, or acquiesces in the commencement of a proceeding or cause of action under any bankruptcy, insolvency, reorganization, or similar law, or has any such petition filed or commenced against it, (ii) makes an assignment or any general arrangement for the benefit of creditors, (iii) otherwise becomes bankrupt or insolvent (however evidenced), (iv) has a liquidator, administrator, receiver, trustee, conservator, or similar official appointed with respect to it or any substantial portion of its property or assets, or (v) is generally unable to pay its debts as they fall due.

1.5 “Business Day” means any day except a Saturday, Sunday, or a federal holiday observed by LPC. Such holidays currently are New Year’s Day, Martin Luther King, Jr. Day, Presidents Day, Memorial Day, Juneteenth National Independence Day, Independence Day, Labor Day, Columbus Day, Veterans Day, Thanksgiving Day, and Christmas Day. A Business Day shall begin at 8:00 a.m. and end at 5:00 p.m. CPT.

1.6 “Capacity Attributes” means any current or future defined characteristic, certificate, tag, credit, or accounting construct associated with the amount of power that the Project can generate at a particular moment and that can be purchased and sold under Applicable Law and market rules or other transactional requirements applicable in the region where the Project is located.

1.7 “Cash” means money denominated in United States Dollars.

1.8 “Claiming Party” has the meaning set forth in Section 16.1.

1.9 “Commercially Reasonable” means, with respect to any action required to be made, attempted, or taken by LPC or Seller under this Agreement, such efforts as a reasonably prudent business would undertake for the protection of its own interest under the conditions affecting such action, including the amount of notice of the need to take such action, the duration and type of action, the competitive environment in which such action occurs, and the risk to the Party required to take such action. With respect to price or cost, Commercially Reasonable means the price or cost obtained or reasonably expected to be obtainable given good faith efforts in a competitive business environment. The price or cost obtained need not necessarily be the lowest or highest (as the case may be) price or cost available at the time so long as such price or cost can be demonstrated to have been reasonably obtained through good faith efforts in a competitive business environment. Commercially Reasonable efforts shall not generally require the payment of fees not otherwise contemplated under this Agreement nor the making of any material financial or other concessions as a condition to accomplishing the result contemplated.

1.10 [Reserved]

1.11 “Contract Price” has the meaning set forth in Section 4.5 and Exhibit A.

1.12 “Contract Output” (CO) is specified in Exhibit D-1.

1.13 “Costs” means, with respect to the Non-Defaulting Party: (a) brokerage fees, commissions, financing breakage fees, and other similar third-party transaction costs (including any related make-whole costs for early prepayment provisions payable to lenders, tax equity investors and other financing parties), and necessary expenses incurred by such Party in a Commercially Reasonable manner (i) as a result of the termination of this Agreement, (ii) in entering into new arrangements that replace this Agreement, or (iii) LPC acquiring the Environmental Attributes and related RECs provided for in Section 4.2, plus (b) all expenses or liabilities incurred in a Commercially Reasonable manner by, or imposed upon or claimed against the Non-Defaulting Party, in connection with the termination of this Agreement pursuant to Section 9.2, or the specific Seller Event of Default described in Section 9.1.

1.14 “CPT” means Central Prevailing Time, meaning prevailing Standard Time or Daylight-Saving Time in the Central Time Zone.

1.15 [Reserved]

1.16 “Curtailement” means any reduction in whole or in part of energy production at the Project to maintain transmission system reliability pursuant to the instruction or other directive made or issued by TVA, any other affected transmission service provider, or any other entity with authority to direct such a reduction of energy production.

1.17 “Defaulting Party” has the meaning set forth in Section 9.1.

1.18 “Delivery Period” means (a) in the case of the first such period (Year 1), the period commencing on the Effective Date and ending on the next December 31<sup>st</sup> that is at least 365 days later, (b) in the case of each such period subsequent to the first such period (but not including the last such period), each twelve (12) calendar months commencing on the January 1<sup>st</sup> next following the end of the prior period (each a “Full Contract Year”), and (c) in the case of the last such period during the Term, the period beginning on the January 1<sup>st</sup> next preceding the final anniversary of the Effective Date and ending on such final anniversary of the Effective Date.

1.19 “Delivery Point” is the point of transmission interconnection to the TVA system, as set forth in Exhibit D-1.

1.20 “Distributor” means the owner or operator of a Distributor’s System.

1.21 “Distributor’s System” means a system within the TVA Power Service Area connected to the TVA transmission system that transmits or distributes electric energy and includes any structures, equipment, or other items used for that purpose.

1.22 “Early Termination Date” has the meaning set forth in Section 9.3.

1.23 “Effective Date” has the meaning set forth in the first paragraph of this Agreement.

1.24 “Electric System” means the network of electric transmission or distribution facilities, equipment, and other devices owned and/or controlled by TVA or the Distributor to which the Project interconnects.

1.25 “Energy Output” means the amount of energy, generated by the Seller and delivered to the Delivery Point, as metered by the Metering Equipment, net of internal, parasitic or auxiliary load, and shall not exceed the Contract Output over any applicable metering interval.

1.26 “Environmental Attributes” means any and all aspects, credits, certificates, claims, characteristics, or benefits associated with the use of a quantity of electrical energy generated by a renewable energy resource and that is capable of being measured, verified, or calculated. Environmental Attributes do not include: (a) federal, state, or local tax credits or other similar incentives; or (b) any avoided adverse wildlife or environmental impacts or avoided emissions of pollutants to the environment.

1.27 “Event of Default” has the meaning set forth in Section 9.1.

1.28 [Reserved]

1.29 “Force Majeure Event” means the following or similar (in nature and severity) event(s): act of God, act of civil or military authority, war, terrorist attacks, riot, insurrection, unplanned mechanical or

electrical failures of equipment (Forced Project Outages), severe weather, change in Applicable Law, blockades, embargoes, sabotage, pandemics, or epidemics, in any of the foregoing cases, which: (i) are outside the reasonable control and without fault or negligence of a Party claiming that such event has occurred, and (ii) directly and actually cause delay(s) in or prevent a Party's performance or completion of critical work. Notwithstanding anything herein to the contrary, (i) economic hardship, (ii) any failure to secure or maintain permits, except to the extent caused by a separate Force Majeure Event, and (iii) inability to obtain or maintain any expected tax benefits are not (separately or together) Force Majeure Event(s).

1.30 "Forced Project Outage" means any reduction or cessation of energy generation by the Project involving the shutdown of, and physical unavailability of generation from, Project facilities caused by any condition at the Project (as opposed to a Curtailment), other than Project Maintenance or Force Majeure Event(s).

1.31 "Full Contract Year" has the meaning set forth in the definition of "Delivery Period."

1.32 "Gains" means with respect to a Non-Defaulting Party, an amount equal to the present value of the economic benefit to it, if any (exclusive of Costs), that directly results from the termination of this Agreement for the remaining term of this Agreement, determined in a Commercially Reasonable manner. Factors used in determining economic benefit may include reference to information either available to it internally or supplied by one or more non-Affiliate third parties, including quotations (either firm or indicative) of relevant rates, prices, yields, yield curves, volatilities, spreads, or other relevant market data in the relevant markets, comparable transactions, forward price curves based on economic analysis of the relevant markets, or settlement prices for comparable transactions at liquid trading hubs in the relevant markets, all of which should be calculated for the remaining term of this Agreement and include the value of Environmental Attributes.

1.33 "Good Utility Practice" means any of the practices, methods, and acts engaged in or adopted by a significant portion of the cogeneration facilities in the electric utility industry during the relevant time period, or practices, methods, and acts that, in the exercise of reasonable judgment in light of the facts known at the time the decision was made, could have been expected to accomplish the desired result at reasonable cost consistent with good business practices, reliability, safety, and expedition. Good Utility Practice is not intended to be limited to any particular set of optimum practices, methods, or acts to the exclusion of all others, but rather is intended to include a spectrum of acceptable practices, methods, or acts generally accepted in the electric utility industry.

1.34 "Governmental Authority" means any nation, government, state, or other political subdivision thereof, whether foreign or domestic, including any municipality, township, and county, and any entity exercising executive, legislative, judicial, regulatory, or administrative functions of or pertaining to government, including any corporation, or any entity owned or controlled by any of the foregoing. The term "Governmental Authority" shall not include TVA when acting in a non-governmental capacity.

1.35 "Governmental Charges" has the meaning set forth in Section 14.2.

1.36 "Interconnection Agreement" means an agreement entered into between Seller and TVA to provide for the interconnection of the Project to TVA's Electric System.

1.37 "kW" means kilowatt or kilowatts, alternating current.

1.38 "kWh" means kilowatt-hour or kilowatt-hours.

1.39 "Losses" means with respect to a Non-Defaulting Party, an amount equal to the present value of the economic loss to it, if any (exclusive of Costs) resulting from the termination of this Agreement for the remaining term of this Agreement, determined in a Commercially Reasonable manner. Factors used in determining the loss of economic benefit may include reference to information either available to it

internally or supplied by one or more non-Affiliate third parties including quotations (either firm or indicative) of relevant rates, prices, yields, yield curves, volatilities, spreads, or other relevant market data in the relevant markets, comparable transactions, forward price curves based on economic analysis of the relevant markets, or settlement prices for comparable transactions at liquid trading hubs in the relevant markets, all of which should be calculated for the remaining term of this Agreement and include the value of Environmental Attributes. If Seller (or Seller's owners or Affiliates, if Seller is a pass-through entity for tax purposes) loses or is required to recapture any tax benefits with respect to the Project because of a breach by LPC, Losses shall include, calculated on an after-tax basis, the amount of such lost or recaptured tax benefits.

1.40 "LPC Fraction" means all Energy Output, with exception for Seller's right to reserve the first 6 MW of capacity for another IP facility, up to LPC's Contract Output defined in Exhibit D-1.

1.41 "Metering Equipment" has the meaning set forth in Section 5.1.

1.42 "Month" means a calendar month commencing at 00:00 CPT on the first calendar day of such month and ending at 24:00 CPT on the last calendar day of such month.

1.43 "Moody's" means Moody's Investors Service, Inc. or its successor.

1.44 "MW" means megawatt or megawatts, alternating current.

1.45 "MWh" means megawatt-hour or megawatt-hours.

1.46 "Non-Defaulting Party" has the meaning set forth in Section 9.3.

1.47 "Other Project Attributes" means, collectively, all applicable Environmental Attributes, Capacity Attributes, and Ancillary Services.

1.48 "Parties" means both LPC and Seller.

1.49 "Party" means either LPC or Seller, as applicable.

1.50 "Permit" means any permit, exemption, approval, license, consent, certification, authorization, concession, order, easement, or other right that is required by any applicable Governmental Authority to develop, construct, finance, operate, or maintain the Project or interconnection facilities or to generate or sell the Project electric output.

1.51 "Person" means an individual, partnership, corporation, limited liability company, joint venture, association, trust, unincorporated organization, Governmental Authority, or other form of legal entity.

1.52 "Product" means, on and after the Effective Date, LPC's Fraction of Energy Output and Other Project Attributes.

1.53 "Project" means the Biomass Asset and all related equipment, structures, electrical lines, and other facilities installed at the Site on Seller's side of the point of interconnection under the Interconnection Agreement that is used for the production, control, delivery, or monitoring of electric energy described in Exhibit D-1.

1.54 "Project Maintenance" means Seller's planned partial or complete reduction of the Project's generating capability for routine maintenance purposes.

1.55 [Reserved]

1.56 “Qualified Bank” means a U.S. commercial bank or a U.S. branch of a foreign bank, with such bank having a credit rating on its senior unsecured debt of (a)(1) “A3” or higher from Moody’s or (2) “A-” or higher from S&P, or (b) if rated by both Moody’s and S&P, both (a)(1) and (a)(2).

1.57 “Renewable Energy Credit” or “Renewable Energy Certificate” or “REC” means a fungible commodity that is created when one megawatt hour (MWh) of electrical energy is created from a renewable energy resource.

1.58 “Renewable Energy Standard” or “RES” means an Applicable Law that requires TVA, LPC or other distributors of TVA power to achieve a percentage of annual electric power sales through production or purchase of specified renewable energy sources and/or through the acquisition of RECs or payment in lieu of the acquisition of RECs.

1.59 “Settlement Amount” has the meaning set forth in Section 9.3.

1.60 “Site” means the land on which the Project is located, as more specifically described in Exhibit D-2.

1.61 “Biomass Asset” means the existing biomass generating facility located at the Site as further described in Exhibit D-1.

1.62 “S&P” means the Standard & Poor’s Rating Group (a division of McGraw-Hill, Inc.) or its successor.

1.63 “Term” has the meaning set forth in Article II.

1.64 “Termination Payment” has the meaning set forth in Section 9.3.

1.65 “TVA” means the Tennessee Valley Authority, a corporate agency and instrumentality of the United States of America created by and existing under and by virtue of the Tennessee Valley Authority Act of 1933, as amended.

1.66 “TVA Power Service Area” means the area served at retail by either TVA or Distributors of TVA power in conformity with section 15d(a) of the TVA Act, as amended, 16 U.S.C. § 831n-4(a).

1.67 “TVA PPA” has the meaning set forth in the recitals above.

## **ARTICLE II: TERM**

This Agreement shall become effective as of the Effective Date and, unless otherwise terminated or extended in accordance with the provisions of this Agreement, shall remain in full force and effect until 24:00 CPT on the 29th day of June, 2028 (“Initial Term”), as defined in the Contract Output and Term Schedule provided for in Exhibit D-1.

In the event that KUB’s Flexibility Capacity Allocation (as described in Exhibit D-1) is not fully utilized by the end of this Initial Term, this Agreement can be extended for additional 1 year terms upon mutual agreement by both parties.

## **ARTICLE III: THE PROJECT**

### **Section 3.1 Project Costs.**

a) KUB will not be responsible under this Agreement for any costs or expenses (including overheads and administrative costs) or risks incurred in connection with the design, construction, installation, operation, or maintenance of any interconnection facilities up to the Delivery Point.

(b) As required by TVA's Generation Flexibility Program, LPC shall provide a copy to TVA of this Agreement within (30) days of the Effective Date, and in producing a copy of this Agreement LPC will redact pricing information from the copy that it provides to TVA.

#### **ARTICLE IV: ENERGY OUTPUT, OTHER PROJECT ATTRIBUTES, AND PRICING**

Section 4.1 Energy Output. Commencing on the Effective Date and continuing through the end of the Term, Seller shall sell and deliver to LPC, and LPC shall purchase and receive from Seller, any and all right, title, and interest in and to LPC's Fraction of the Energy Output at the Delivery Point. Energy Output shall be deemed made available to LPC for billing and payment purposes under Section 4.5, Article X, and Exhibit A in the Month in which Energy Output is made available at the Delivery Point.

Section 4.2 Environmental Attributes. In accordance with and subject to the terms and conditions of this Agreement, commencing on the Effective Date and continuing through the end of the Term, LPC shall have any and all right, title, and interest in and to Environmental Attributes, as applicable, equal to the amount of LPC's Fraction of Electrical Energy Output. Seller shall execute all necessary documentation, bear all cost, and take all other necessary action to register, receive, authenticate, attest, and transfer to LPC any and all RECs and other Environmental Attributes as promptly as practicable; provided that issuance of RECs shall be in accordance with a tracking or certification system selected by LPC. RECs and other Environmental Attributes shall be for use and disposition as determined only by LPC or any entity to whom LPC may grant permission to market, transfer, or otherwise dispose of the RECs or other Environmental Attributes; and neither such Environmental Attributes nor the associated energy shall be claimed or otherwise referenced by Seller with respect to any RES, renewable energy goal, Federal, state, or local renewable energy requirement, renewable energy procurement, renewable portfolio standard, or other renewable energy mandate, standard, or commitment. Seller agrees to be at all times fully compliant with the requirements of the Federal Trade Commission's "Green Guides," 77 Federal Register 62122, 16 Code of Federal Regulations, Part 260, in any communication concerning the Project, energy from the Project, or the RECs. LPC prohibits Seller from collecting for its benefit cryptocurrency based upon or relating to the renewable generation, such as "SolarCoin." Representations by Seller or any other entity that imply use of, title to, or interest in LPC's Fraction of the renewable energy are prohibited except as LPC may permit.

Section 4.3 Capacity Attributes. In accordance with and subject to the terms and conditions of this Agreement, commencing on the Effective Date and continuing through the end of the Term, Seller shall deliver to LPC, and LPC shall receive from Seller, any and all right, title, and interest in and to LPC's Fraction of Capacity Attributes available with respect to the Project.

Section 4.4 Ancillary Services. In accordance with and subject to the terms and conditions of this Agreement, commencing on the Effective Date and continuing through the end of the Term, Seller shall transfer to LPC, and LPC shall receive from Seller, any and all right, title, and interest in and to LPC's Fraction of Ancillary Services available with respect to the Project. Ancillary Services shall include the provision of primary frequency response with a maximum 5 percent droop and  $\pm 0.036$  Hz deadband. Seller's provision of Ancillary Services shall be at no additional cost to LPC.

Section 4.5 Pricing.

(a) The "Contract Price" is set forth in Exhibit A.

(b) In consideration for the Product, LPC shall pay Seller the applicable Contract Price, as adjusted, for each hour that TVA purchases from LPC from the project.

## **ARTICLE V: METERING AND ATTESTATION**

Section 5.1 Metering Arrangements. Seller shall enter into separate contractual arrangements with TVA, as the case may be, for the installation, operation, maintenance, and reading of the metering and related facilities ("Metering Equipment"). The Metering Equipment shall be used to determine the amount of energy delivered to and purchased by LPC at the Delivery Point under this Agreement.

Section 5.2 Meter Testing. These separate arrangements shall provide for TVA, as the case may be, to perform periodic tests and inspections of the Metering Equipment in order to maintain a high standard of accuracy. If tests show that the meter(s) are accurate within an acceptable threshold, fast or slow, as set forth under the separate arrangements, no adjustment shall be made to the payments submitted by LPC to Seller pursuant to Section 10.2. In case any tests show the meter(s) to exceed the acceptable threshold, fast or slow, adjustments shall be made to the payments submitted by LPC to Seller pursuant to Section 10.2 for any known or agreed upon period of inaccuracy; in the absence of any such knowledge or agreement, the adjustment shall be limited to one-half the period of time from the date of the last previous test of the meter(s) and the most recent test, but in no event shall the period covered by the correction exceed one hundred eighty (180) days.

Section 5.3 Attestations. Upon LPC's reasonable request, Seller shall provide, at no cost to LPC, routine attestations and other verifications of the delivery of any or all of the Energy Output and Other Project Attributes from the Project to demonstrate performance under this Agreement.

## **ARTICLE VI: MAINTENANCE AND OUTAGES**

Section 6.1 Scheduled Outages. Seller shall provide, or cause to be provided, to LPC and TVA (if required by the Interconnection Agreement) a schedule for Project Maintenance no later than thirty (30) calendar days before the Effective Date for the period from such date through the end of the first Delivery Period. Seller shall submit to LPC and TVA (if required by the Interconnection Agreement) a schedule for Project Maintenance no later than each subsequent December 1st, applicable to the following calendar year. To the extent practicable, Project Maintenance will be scheduled during the Months of October, November, March, and April, or during non-daylight hours.

Section 6.2 Forced Project Outages. As soon as practicable after commencement of a Forced Project Outage, Seller shall provide LPC and TVA with notice and expected duration of such Forced Project Outage. Each such notice shall set forth, to the extent of Seller's knowledge and judgment, a detailed explanation for the cause of the Forced Project Outage, identification of the equipment impacted, the expected duration of the Forced Project Outage, and Seller's proposed course of action to remedy such event and prevent similar future events.

Section 6.3 Project Description and Characteristics. Exhibit D-1 provides a detailed description of the Project. Exhibit D-2 provides additional information with respect to major equipment and components expected to make up the Project. Seller shall provide advance written notice to LPC and TVA at the earliest practicable time of any material proposed changes to Exhibit D-1. Seller shall also provide advance written notice to LPC at the earliest practical time regarding any proposed changes to equipment that may alter generation capabilities other than capacity or items set forth in Exhibit D-1. Seller shall also report to LPC and TVA any material changes to Exhibit D-1.

## **ARTICLE VII: RESERVED**

## **ARTICLE VIII: DISCONNECTION AND CURTAILMENT**

Section 8.1 Disconnection of Project or Curtailment of Deliveries. In order to remain consistent with Good Utility Practice and/or in compliance with Applicable Law, or in compliance with the Interconnection Agreement, TVA may require Seller: (1) to effect a Curtailment of deliveries from the Project



or (2) to temporarily disconnect the Project from the TVA transmission system as necessary or appropriate to eliminate adverse impacts attributable to operation of the Project, including the following circumstances, whether such circumstances exist on the TVA transmission system or another system:

- (a) if a condition exists that presents an imminent physical threat to persons or property and disconnection or Curtailment appears necessary to protect such persons or property; or
- (b) to overcome transmission or distribution system reliability problems; or
- (c) if such disconnection or Curtailment is necessary to construct, install, maintain, repair, replace, remove, investigate, inspect, or test any affected part of the TVA transmission system; or
- (d) to comply with applicable NERC standards, including those relating to TVA's role as a balancing authority; or
- (e) as permitted under any other express provisions of this Agreement or under the Interconnection Agreement that provide for any such disconnection or Curtailment.

Section 8.2 Economic Curtailment. Notwithstanding the foregoing, the Parties acknowledge that TVA shall have the right to curtail Project energy based on TVA power system cost in order to effectively manage the economics of the overall TVA power system. For any Month in which TVA has curtailed the Project for economic reasons, LPC shall pay Seller, in addition to amounts otherwise due, an amount equal to the Contract Price multiplied by the estimated amount of such curtailed energy. The Parties shall estimate the expected amount of such economically curtailed energy that would have been generated but for the curtailment, in a Commercially Reasonable manner, consistent with Good Utility Practice for each hour during the economic curtailment period. For the avoidance of doubt, a curtailment by LPC for any reason other than as set forth in Section 1.16 or Section 8.1 (but excluding Section 8.1(e)) shall constitute an economic curtailment subject to this Section 8.2.

## **ARTICLE IX: DEFAULT, EARLY TERMINATION, AND REMEDIES**

Section 9.1 Events of Default. An "Event of Default" means, with respect to a Party (a "Defaulting Party"), the occurrence of any of the following:

- (a) the failure by a Party to make, when due, any payment required pursuant to this Agreement, including a failure to pay liquidated damages, if such failure is not remedied within twenty (20) Business Days after receipt of written notice from the other Party;
- (b) any representation or warranty made by such Party in Section 15.1 is false or misleading in any material respect as of the Effective Date, or with regard to the representations or warranties set forth in Section 15.1(a) through (d), becomes false and misleading in any material respect at any time during the Term of this Agreement, and such Party fails to take such action as may be necessary to make such representations and warranties not false and misleading in all material respects within thirty (30) Business Days after receipt of written notice from the other Party;
- (c) the failure to perform any material covenant or obligation set forth in this Agreement (except to the extent addressed as a separate Event of Default under another subsection of this Section 9.1, and except for the failure of Seller or LPC to comply with an obligation under this Agreement for which a specific remedy has been agreed upon) if such failure is not remedied within thirty (30) calendar days after written notice from the other Party; provided, however, that if such failure is not reasonably capable of being remedied within the thirty (30) day cure period, such Party may have up to an additional fifteen (15) calendar days to remedy such failure, so long as such Party promptly commences and diligently pursues such remedy and provides to the other Party a written action plan therefor;

(d) the filing of an involuntary petition in bankruptcy or any involuntary proceeding under any other insolvency law against a Party as debtor and the failure to have the same dismissed within one hundred and twenty (120) calendar days from the date of filing;

(e) the filing by a Party of a voluntary petition in bankruptcy or for insolvency or reorganization or arrangement under the bankruptcy laws of the United States or under any insolvency act of any state, or a Party voluntarily taking advantage of any such law or act by answer or otherwise;

(f) such Party consolidates or amalgamates with, or merges with or into, or transfers all or substantially all of its assets to, another entity and, at the time of such consolidation, amalgamation, merger, or transfer, the resulting surviving or transferee entity fails to assume all the obligations of such Party under this Agreement to which it or its predecessor was a party by operation of law or pursuant to an agreement reasonably satisfactory to the other Party;

(g) the Biomass Asset at any time after the Effective Date fails to generate and deliver electric power and energy exclusively from biomass by means of generation set forth in Exhibit D-1, provided, however, that LPC acknowledges and agrees that there are no guaranteed or promised generation volumes from the Biomass Asset;

(h) Seller makes sales or transfers of LPC's Fraction of Electrical Energy Output or Environmental Attributes to any third party, or makes claims that trigger retirement of any of LPC's RECs or other Environmental Attribute associated with the Project;

(i) Seller's failure to deliver LPC's Fraction of any Other Project Attributes associated with the Project; provided, however, that LPC acknowledges and agrees that there are no guaranteed or promised generation volumes from the Biomass Asset.

(j) Seller breaches or causes an event of default under the Interconnection Agreement, or any other written agreement between Operator and TVA that is necessary for TVA to receive Energy Output (each an "Operator Agreement") and such event of default is not cured by the time provided in said agreement.

Notwithstanding the provisions of subsection (i), in the event that Seller breaches or causes an event of default under a Operator Agreement (each, an "Operator Default"), such occurrence shall not become an Event of Default unless TVA serves a copy of any written notice of such Operator Default on LPC. Notwithstanding anything to the contrary in this Agreement or in the relevant Operator Agreement, LPC shall have the right to cure, or cause to be cured, the Operator Default at any time within thirty (30) days after LPC receives notice of such Operator Default from TVA, and if LPC determines that such Operator Default (other than a monetary Operator Default) cannot be cured within such thirty (30) day period, LPC shall have such further time to cure the Operator Default as is reasonably necessary so long as LPC promptly provides notice to TVA of its intent to cure and LPC proceeds with reasonable diligence to cure the Operator Default. Notwithstanding LPC's cure rights with regard to a Operator Default under this paragraph, TVA will continue to have the right to exercise remedies under the Operator Agreement other than termination of the Operator Agreement, including remedies related to safety, reliability, performance assurance, and suspension of performance.

#### Section 9.2 Remedies for an Event of Default.

(a) Subject to Article XIII, Seller shall have the right, but not the obligation, to do one or more of the following upon the occurrence of, and after providing written notice to LPC of, LPC's Event of Default:

(i) suspend performance of its obligations under this Agreement, including withholding any payments due to LPC under this Agreement; provided, however, in no event shall any such suspension continue for longer than ten (10) Business Days unless an Early Termination Date shall have been declared and notice thereof given pursuant to Section 9.3; or

(ii) declare an Early Termination Date and cease supply of generation and Other Project Attributes to LPC.

(b) Subject to Article XIII, LPC shall have the right, but not the obligation, to do one or more of the following upon the occurrence of, and after providing written notice to Seller of, Seller's Event of Default:

(i) suspend performance of its obligations under this Agreement, including withholding any payments due to Seller under this Agreement; provided, however, in no event shall any such suspension continue for longer than ten (10) Business Days unless an Early Termination Date shall have been declared and notice thereof given pursuant to Section 9.3;(ii) declare an Early Termination Date and cease accepting generation and Other Project Attributes from Seller, or

(iii) seek and obtain specific performance of Seller's obligations under this Agreement, but only with regard to an Event of Default occurring if LPC has not exercised any right it has to terminate this Agreement.

The remedies set forth in this Section 9.2 shall constitute the Non-Defaulting Party's sole and exclusive remedies for an Event of Default.

**Section 9.3 Declaration of an Early Termination Date and Calculation of Settlement Amounts.** If an Event of Default with respect to a Defaulting Party occurs and is continuing, the other Party ("Non-Defaulting Party") may designate a day, no earlier than the day such notice is effective and no later than twenty (20) calendar days after such notice is effective, as an early termination date ("Early Termination Date") to accelerate all amounts then owing between the Parties and to liquidate and terminate this Agreement. The Non-Defaulting Party shall calculate, in a Commercially Reasonable manner, a Settlement Amount for this Agreement as of the Early Termination Date. In making the calculation described in the foregoing sentence, the "Settlement Amount" means the Non-Defaulting Party's Losses or Gains, and Costs, expressed in U.S. Dollars, which such Party incurs as a result of the liquidation and termination of this Agreement pursuant to this Section. The Non-Defaulting Party shall aggregate the Settlement Amount with all other amounts due to the Non-Defaulting Party under this Agreement so that all such amounts constitute a single liquidated amount (the "Termination Payment"). For the purposes of clarity, in no case shall Seller or LPC be entitled to, nor seek remuneration for, any future benefits that would have been realized had this agreement continued through its expiration date. Any estimated or anticipated benefits of this agreement are not amounts then owing between the Parties to be accelerated upon termination of this Agreement.

**Section 9.4 Notice of Termination Payment Amount.** As soon as practicable after a declaration of an Early Termination Date, the Non-Defaulting Party shall give notice to the Defaulting Party of the amount of the Termination Payment (if any). The notice shall include a request for payment and a written statement explaining in reasonable detail the calculation of such amount and the sources for such calculation. The Defaulting Party shall pay the any undisputed portion of the Termination Payment to the Non-Defaulting Party within five (5) Business Days after receiving a request for the same.

**Section 9.5 Disputes with Respect to Termination Payment.** If the Defaulting Party disputes the Non-Defaulting Party's calculation of the Termination Payment, in whole or in part, the Defaulting Party shall, within five (5) Business Days after receipt of Non-Defaulting Party's calculation of the Termination Payment, provide to the Non-Defaulting Party a detailed written explanation of the basis for and extent of such dispute.

Section 9.6 Early Termination for Convenience. Either party can terminate for convenience, at its sole discretion and without penalty, with three hundred sixty-five (365) days' notice during the term. In such event, Parties agree that no Termination Payment will be due.

## **ARTICLE X: BILLING AND PAYMENT**

Section 10.1 Billing. Based on recorded meter data provided by the Metering Equipment installed per Section 5.1 ("Meter Readings"), and after receipt of an invoice, LPC shall pay Seller the Contract Price for LPC's Fraction of the Energy Output from the Project to Seller each Month of the Term. LPC or TVA shall provide Seller with a detailed accounting of the amount of Energy Output received for such Month.

Section 10.2 Payment. Seller must provide an invoice to LPC based on said Meter Readings within ten (10) Business Days following the Month of actual energy delivery (provided that such time period shall be extended as necessary to the extent LPC or TVA is delayed in providing Seller the Meter Readings). Upon receipt of such invoice, LPC shall promptly pay Seller within thirty-five (35) calendar days or if the thirty-fifth (35<sup>th</sup>) calendar day is not a Business Day, then on the next Business Day. Each payment to Seller shall be made electronically through the Automated Clearing House (ACH) network to Seller's account as designated by Seller. Any delays by Seller in invoicing LPC for any reason shall in no way limit the requirement of LPC to pay valid and accurate invoices from Seller.

Section 10.3 Invoice Submittal. Seller shall submit all invoices, including supporting documentation, electronically to LPC at [AccountsPayable@kub.org](mailto:AccountsPayable@kub.org).

Section 10.4 Netting. Amounts owed by each Party to the other Party during a monthly billing period under this Article X shall be offset against each other so that only one Party shall pay a net amount to the other Party.

## **ARTICLE XI: ASSIGNMENT**

Section 11.1 Assignment.

(a) Except as otherwise expressly set forth in this Section, neither Party will assign this Agreement nor any of its rights or obligations hereunder without the prior, written consent of the other Party, which consent shall not be unreasonably withheld, conditioned, or delayed. Without such consent from LPC, Seller may assign, transfer, or pledge its interest in the revenues and payments to be made under this Agreement. In the event Seller's rights, interests, or obligations under this Agreement are assigned or assumed as a matter of law to an entity with which Seller is merged, consolidated or sold ("Successor Seller"), any such assignment or assumption shall be contingent upon Seller and Successor Seller furnishing LPC with reasonably adequate assurances that the Successor Seller is financially capable of performing Seller's obligations under this Agreement. No assignment, transfer, or pledge of Seller's or a Successor Seller's interests in the Agreement shall release the assignor, pledger, or transferor from any of its obligations under this Agreement to accrue prior to such assignment, transfer, or pledge. Except as stated above, either Party's purported assignment of this Agreement, in whole or in part, without the prior, written approval of the other Party is null and void.

## **ARTICLE XIII: LIMITATIONS**

Section 13.1 Limitations of Liability.

UNLESS EXPRESSLY HEREIN PROVIDED, NEITHER PARTY WILL BE LIABLE TO THE OTHER PARTY FOR CONSEQUENTIAL, INCIDENTAL, PUNITIVE, EXEMPLARY, OR INDIRECT DAMAGES,

LOST PROFITS, OR OTHER BUSINESS INTERRUPTION DAMAGES, IN TORT OR CONTRACT, UNDER ANY PROVISION OF THIS AGREEMENT. THE LIMITATIONS OF LIABILITY STATED IN THIS SECTION ARE IMPOSED WITHOUT REGARD TO THE CAUSE OR CAUSES RELATED THERETO, INCLUDING THE NEGLIGENCE OF EITHER PARTY, WHETHER SUCH NEGLIGENCE BE SOLE, JOINT, OR CONCURRENT, OR ACTIVE OR PASSIVE.

#### **ARTICLE XIV: GOVERNMENTAL CHARGES**

Section 14.1 Cooperation. Each Party shall use Commercially Reasonable efforts to minimize all taxes, so long as neither Party is materially adversely affected by such efforts.

Section 14.2 Governmental Charges. Seller shall pay or cause to be paid all taxes imposed by any Governmental Authority ("Governmental Charges") on or with respect to the Product arising prior to the Delivery Point. LPC shall pay or cause to be paid all Governmental Charges on or with respect to the Product at and from the Delivery Point (other than ad valorem, franchise, or income taxes that are related to the sale of the Product and are, therefore, the responsibility of Seller). If Seller is required by Applicable Law to remit or pay Governmental Charges that are LPC's responsibility hereunder, LPC shall promptly reimburse Seller for such Governmental Charges. If LPC is required by Applicable Law to remit or pay Governmental Charges that are Seller's responsibility hereunder, LPC may offset the amount of any such Governmental Charges against sums due to Seller under this Agreement. Nothing shall obligate or cause a Party to pay or be liable to pay any Governmental Charges for which it is exempt under Applicable Law. Each Party shall reasonably cooperate with the other Party to qualify for or take advantage of any available reduction in or exemption from such Governmental Charges and to otherwise minimize the amount of such Governmental Charges that must be paid under Applicable Law.

#### **ARTICLE XV: REPRESENTATIONS AND WARRANTIES**

Section 15.1 Representations and Warranties. As of the Effective Date, each Party represents and warrants to the other Party that:

(a) it is duly organized, validly existing, and in good standing under the laws of the jurisdiction of its formation;

(b) it has all regulatory authorizations necessary for it to legally perform its obligations under this Agreement, except those authorizations which Seller reasonably expects to receive in the ordinary course, e.g., those required to be obtained from or with the cooperation of TVA or LPC;

(c) the execution, delivery, and performance of this Agreement are within its powers, have been duly authorized by all necessary action, and are not inconsistent with any of the terms and conditions in its governing documents, any contracts to which it is a party, or any Applicable Law;

(d) this Agreement and each other document executed and delivered in accordance with this Agreement constitutes its legally valid and binding obligation enforceable against it in accordance with its terms, subject to any equitable defenses;

(e) it is not Bankrupt and there are no proceedings pending or being contemplated by it or, to its knowledge, threatened against it that would result in it being or becoming Bankrupt;

(f) there is not pending or, to its knowledge, threatened against it or any of its Affiliates, any legal proceedings that could materially adversely affect its ability to perform its obligations under this Agreement;

(g) nothing which would constitute an Event of Default with respect to it has occurred and is continuing and no such event or circumstance would occur as a result of its entering into or performing its obligations under this Agreement;

(h) it is acting for its own account, has made its own independent decision to enter into this Agreement and as to whether this Agreement is appropriate or proper for it based upon its own judgment, is not relying upon the advice or recommendations of the other Party in so doing, and is capable of assessing the merits of and understanding, and understands and accepts, the terms, conditions, and risks of this Agreement;

(i) the Parties intend for this Agreement to be a forward contract” as defined in 11 U.S.C. § 101(25);

(j) it has entered into this Agreement in connection with the conduct of its business and it has the due capacity or ability to make or take delivery of all Products referred to in this Agreement;

(k) with respect to the purchase or sale of a Product, it is a producer, processor, commercial user, or merchant handling the Product, and it is entering into this Agreement for purposes related to its business as such; and

(l) it is an “eligible contract participant” within the meaning of the United States Commodity Exchange Act.

**EXCEPT AS SET FORTH EXPLICITLY IN THIS AGREEMENT, THERE IS NO WARRANTY OF MERCHANTABILITY OR FITNESS FOR A PARTICULAR PURPOSE, AND ANY AND ALL IMPLIED WARRANTIES ARE DISCLAIMED.**

#### **ARTICLE XVI: FORCE MAJEURE**

Section 16.1 Force Majeure Occurrence and Notice. To the extent that any Party is prevented by a Force Majeure Event from performing, in whole or in part, its obligations under this Agreement (other than the obligation to pay money) or from complying with, in whole or in part, requirements under this Agreement, such Party (the “Claiming Party”) shall not be liable to the other Party for any failure to meet the obligations under this Agreement for the duration of the Force Majeure event. The Claiming Party shall give notice and details of the Force Majeure Event to the other Party as soon as practicable. In addition, any completion milestones or deadlines or time periods by which performance is due will be extended for a period of time equal to the time period during which such Force Majeure Event actually prevents the Claiming Party’s performance. The Claiming Party shall use Commercially Reasonable efforts to remedy the Force Majeure Event and mitigate any adverse effects on the performance of its obligations under this Agreement. The Claiming Party shall promptly notify the other Party when it is able to resume performance of its obligations and compliance with such conditions under this Agreement if it is able to do so. Until the other Party is so notified, it shall not be required to perform or resume performance of its obligations to the Claiming Party corresponding to the obligations of the Claiming Party excused by a Force Majeure Event. No Party will be relieved or excused by operation of this Article XVI of any liability for breach of any obligations that were to be performed or that accrued before the Force Majeure Event. If the Force Majeure Event reduces the amount of generation but does not prevent entirely Seller from generating and delivering available Energy Output and Other Project Attributes, then Seller shall generate and deliver available Energy Output and Other Project Attributes at Seller’s discretion. If deliveries of Energy Output or Other Project Attributes are prevented in whole or in part by a Force Majeure Event, the deliveries in question shall not be made up and the Term shall not be extended to permit any makeup or offset of the lost deliveries.

#### **ARTICLE XVII: MISCELLANEOUS**

Section 17.1 Title. Delivery of LPC’s Fraction of Energy Output and Other Project Attributes being purchased by LPC shall be deemed completed at the Delivery Point, and title to such Energy Output and Other Project Attributes shall pass to LPC upon delivery thereto.

Section 17.2 Waiver. The non-exercise of, or delay in exercising, any power or right of a Party does not operate as a waiver of that power or right, nor does any single exercise of a power or right preclude any other or further exercise of it or the exercise of any other power or right. A power or right may only be waived in writing, signed by the Party to be bound by the waiver.

Section 17.3 Choice of Law. This Agreement shall be governed, construed and interpreted in accordance with the laws of the State of Tennessee.

Section 17.4 Exhibits Made Part of this Agreement. The Exhibits attached to this Agreement are made a part of this Agreement.

Section 17.5 Approvals. Each Party hereto shall use Commercially Reasonable efforts and shall cooperate with the other to obtain any Permit. LPC, however, shall not be obligated to obtain any Permit or have financial responsibility for obtaining any Permit.

Section 17.6 Severability. In the event that any of the terms, covenants, or conditions of this Agreement or the application of any such term, covenant, or condition shall be held invalid by any court or administrative body having jurisdiction, it is the intention of the Parties that in lieu of each such term, covenant, or condition that is held invalid, the Parties shall negotiate a valid term, covenant, or condition as similar in effect as possible to such invalid term, covenant, or condition. The Agreement shall not otherwise be affected thereby and shall remain in full force and effect.

Section 17.7 Integration. The terms and provisions contained in this Agreement between the Parties constitute the entire agreement between the Parties, and supersede all previous communications and representations, either oral or written, between the Parties with respect to the subject matter of this Agreement.

Section 17.8 Notices and Payments.

(a) Notices. Except as otherwise expressly provided under this Agreement, any notice provided for in this Agreement must be in writing and shall be effective on the day on which it is actually received (provided that such day is a Business Day, otherwise it shall be deemed to be received on the first Business Day immediately following such day), in person, by U.S. Mail, by other nationally recognized delivery service, or by e-mail at the addresses provided set forth below:

If to LPC:

KNOXVILLE UTILITIES BOARD  
445 S. Gay Street  
Knoxville, Tennessee 37902  
Attention: President and Chief Executive Officer  
Email: [execdept@kub.org](mailto:execdept@kub.org)

If to Seller:

**Attention: Denise Martin**

Director Raw Materials and Energy  
Global Cellulose Fibers  
6400 Poplar Ave, Memphis TN 38197  
Email : [denise.martin@ipaper.com](mailto:denise.martin@ipaper.com)  
Phone: 901-419-8800

**Attention: Gwendolyn Kielman**

Mill Controller, Finance and Planning  
Columbus Mill  
4335 Carson Road, Columbus, MS 39703  
Email : [gwen.kielman@ipaper.com](mailto:gwen.kielman@ipaper.com)  
Phone: 662-243-4273

(b) Payments. All payments required to be made to LPC under this Agreement shall be made by Automated Clearing House (ACH) to the following account (or to other account as may subsequently be

designated by LPC), with the amounts deemed received as of the date the electronic fund transfer to the recipient's account is deemed effective:

Depository Institution Name: First Horizon Bank  
Address: Memphis, TN  
ABA Routing Number: 084000026  
Receiving Company Name: KNOXVILLE UTILITIES BOARD  
Account Number: 179318042  
Employer Identification No (EIN): 62-6000324

All payments required to be made to Seller under this Agreement shall be made by wire to:

Bank name: J.P.Morgan Chase Bank  
Account #: 9102524965  
Numeric bank key (ABA#): 021000021  
SWIFT: CHASUS33  
New York NY 10081  
United States Of America

Section 17.9 Audit.

(a) The Parties shall maintain accurate records and books of account. Said books and records shall present fairly all costs and expenses utilized in computing any charges or payments to the other Party under this Agreement.

(b) Each Party shall have the right at its own expense, upon 90 Business Days' advance notice and during normal business hours, to have its own personnel or its independent auditors inspect the books and records of the other Party hereto pertaining solely to the performance of this Agreement at the offices of the other Party, to the extent expressly necessary to verify the amounts of energy delivered, the amounts owed to Seller by LPC, and any amount owed to LPC by Seller. The Party conducting the inspection shall use its best efforts to minimize any disruptions of the other Party's operations that might result from any such inspection.

Section 17.10 Dispute Resolution. Unless otherwise provided in this Agreement, the Parties agree to use commercially reasonable efforts to resolve disputes related to this Agreement informally at the lowest possible levels of decision making. Disputes not resolved at the working level will be referred to higher levels of management of both Seller and LPC for consideration, as necessary, and resolution, if possible. Any legal or equitable action related to this Agreement shall be brought in the United States District Court for the Eastern District of Tennessee and THE PARTIES HEREBY WAIVE: (a) ANY OBJECTION TO THAT COURT'S JURISDICTION OVER THEM, OR THAT VENUE IS PROPER IN SUCH COURT, AND (b) ANY RIGHT TO A JURY TRIAL.

Section 17.11 Indemnity and Insurance.

(a) Seller shall indemnify, defend, save, and hold harmless LPC and its directors, officers, employees, contractors, and agents from any and all third-party claims for injury to persons or damage to property or the environment, including any adverse wildlife or environmental impacts, to the extent caused by: (i) Seller's negligent, reckless, or intentional acts or omissions in conducting activities within the scope of this Agreement, or (ii) Seller's failure to comply with Applicable Law or the specific environmental requirements concerning the Project that are set forth in TVA's Notice of Environmental Review Completion. Seller is solely responsible for the risk of loss of, or damage to, the Project, Site, or adjacent properties to the Site, except to the extent that the loss or damage results from the reckless or intentional acts or omissions of LPC and its directors, officers, employees, contractors, or agents.



(b) Seller shall maintain or cause to be maintained the insurance required by Exhibit B. Failure of Seller to do so shall be deemed a failure to perform a material covenant or obligation set forth in Section 9.1(c).

Section 17.12 Interpretation. Unless otherwise expressly stated, references in this Agreement to "Sections" are to Sections of this Agreement, references to "Articles" are to Articles of this Agreement, and references to "Exhibits" are to the Exhibits attached to this Agreement. All references to Sections in the Exhibits to this Agreement are to the Sections in the Exhibits in which they appear unless otherwise noted. All titles, headings, and similar items are provided for the purpose of reference and convenience and are not intended to affect the meaning of the contents or scope of this Agreement. Words defined in the singular have the corresponding meaning in the plural and vice versa. Use of "including" means including without limitation. References to one gender include all others. Any capitalized terms used in the Exhibits to this Agreement that are not specifically defined in such Exhibits shall have the meanings ascribed to them in this Agreement. Such Exhibits shall constitute a material part of this Agreement, and the provisions of such Exhibits shall be interpreted and enforced as if such provisions were directly set forth in this Agreement.

Section 17.13 No Partnership or Agency. Nothing in this Agreement shall be treated as creating a partnership or joint venture between the Parties under Applicable Law and, except as specifically provided in this Agreement, neither Party may act or have any authority to act as agent of or in any way bind or commit the other Party to any obligation.

Section 17.14 Costs and Expenses. Each Party shall bear and is responsible for its own costs (including attorney fees) in connection with the negotiation, preparation, execution, completion, implementation, and ongoing administration of this Agreement.

Section 17.15 Rights Cumulative. Except as specifically provided in this Agreement, the rights and remedies provided in this Agreement are cumulative with and do not exclude any rights or remedies provided by law.

Section 17.16 Amendment. This Agreement may be amended, changed, modified, altered, or extended, provided that such amendment, change, modification, alteration, or extension shall be in writing and signed by both Parties.

Section 17.17 Survival of Obligations. Except as specifically provided in this Agreement, cancellation, expiration, or early termination of this Agreement shall not relieve the Parties of obligations that by their nature should survive such cancellation, expiration, or termination, including warranties, remedies, and promises of indemnity.

Section 17.18 Counterparts. This Agreement may be executed in two or more counterparts, each of which is signed by one of the Parties but all of which together shall constitute but one and the same agreement.

Section 17.19 Confidentiality.

Confidentiality/Trade Secrets. All nonpublic technical specifications, operating processes, plant capacities, product prices, strategies, partners and other nonpublic commercial information furnished by Seller, or its agents, to LPC in connection with this Agreement remain the exclusive intellectual property of Seller and will be treated by the LPC as proprietary and will not be disclosed or used, outside the limitation of this Agreement, without prior written approval of Seller's Vice President.

The composition, design, operation, pricing and application of LPC's generation, transmission and distribution products and services remain the exclusive intellectual property of LPC and will be treated by the Seller as proprietary and will not be disclosed or used, outside the limitation of this Agreement, without prior written approval of the LPC. Nothing herein will be construed as prohibiting Seller from identifying general products for purposes of future requests for proposal with LPC or other entities.

A receiving party's obligation of confidence and nonuse will survive for a period of two (2) years beyond the termination or expiration of this Agreement, and will not apply to information which (a) is, or without fault of the receiving party becomes available to the general public; (b) was known to the receiving party prior to receipt hereunder as can be evidenced by writing in the receiving party's possession; (c) is lawfully received by the receiving party from a third party without binder of secrecy and not as result of misappropriation by third party; (d) the receiving party can reasonably demonstrate was developed by employees of the receiving party who had at the time no direct or indirect access to the relevant disclosing party information; or (e) is disclosed without an obligation of confidence under operation of law, governmental regulation or court order, provided the receiving party first gives the disclosing party notice and uses all reasonable efforts to secure confidential protection of such information. As a municipal utility LPC is subject to the requirements of the Tennessee Public Records Act ("PRA"), and LPC's obligations under this section are subject to the requirements of the PRA.

In addition, this Agreement does not authorize the LPC to use the name of or make reference to Seller for any purpose in any releases for public or private dissemination, nor will the LPC divulge or use in any advertisement or publication any specifications, data, or other information pertaining to or relating to Seller without prior written approval of the Vice President of Seller.

Section 17.20 Project Communications. Seller will, when communicating publicly about the Project and associated RECs, identify LPC and TVA (by name or by LPC or TVA logo) in promotional efforts and materials associated with the Project. Use of the LPC and TVA logos must follow LPC's and TVA's logo use guidelines, as applicable. If Seller intends to include language expressly referencing LPC or TVA (or using LPC's or TVA's logos), Seller must provide such language to LPC and TVA in advance for approval. Seller will notify LPC and TVA of public events in advance to enable reasonable efforts to participate. LPC acknowledges that, by executing this Agreement, it has obtained the right for Seller to use LPC's name and logo as prescribed in this Section 17.20. For the avoidance of doubt, this Section 17.20 does not prohibit Seller from making any public statements about the Project (i) as required by Applicable Law, including in connection with public permitting proceedings or filings, or (ii) without reference to LPC or TVA as required in the ordinary course of development, construction, and operations and maintenance activities, such as, by way of example, public hearings to obtain zoning variances or development or construction permits.

Section 17.21 Project Collaboration. Parties will endeavor to find mutually agreeable opportunities for education and research that benefit the Parties, and/or specific LPC or TVA customers or specific customers served by Distributors of TVA power receiving the benefit of Environmental Attributes associated with the Project.

Section 17.22 Service Contract. Each Party intends this Agreement to be a "service contract" within the meaning of Section 7701(e)(3) of the Internal Revenue Code of 1986.

Section 17.23 TVA FOPPA. If the TVA FOPPA terminates without renewal or extension prior to the termination of this Agreement, Seller and LPC shall use Commercially Reasonable efforts to (i) arrange for the sale and delivery of LPC's Fraction of Energy Output to TVA, another Participating LPC, or another Distributor under such alternative arrangements as may be negotiated between LPC and such other Person, as applicable (subject to any conditions or restrictions imposed by TVA's Power Supply Expanded Flexibility Program), or (ii) to deliver or arrange transmission service, including Firm Transmission Service if needed, for the delivery of all or any portion of the Energy Output to one or more third-party purchasers of Energy Output.

Section 17.24 Other Covenants of Seller. Seller is responsible, at its sole cost and expense, for complying with the following obligations of LPC under TVA's Power Supply Expanded Flexibility Program Guidelines that are in effect as of the Effective Date (the "Guidelines"), a copy of which is attached as Exhibit E to this Agreement:

- (i) Participating in any "Facilities Study," "System Impact Study," "Transmission Screen" and providing any "Flexibility Device Kit," as each such term is defined in the Guidelines;

(ii) Complying with all “Interconnection Requirements”, “Commissioning Requirements”, “Modeling Requirements”, and “TVA Operating Procedures” and related requirements, as such terms and requirements are specified in the Guidelines; provided, however, that the Interconnection Agreement and TVA’s published interconnection procedures shall control all matters relating to the interconnection of the Project to the TVA Electric System;

(iii) Installing any protection equipment and taking any actions determined by TVA to be necessary to address any adverse impacts on TVA’s transmission system that will be caused by the installation or operation of the Project, and reimbursing TVA for any equipment costs incurred by TVA in connection with addressing these transmission system impacts, all in accordance with TVA’s published interconnection procedures and the Interconnection Agreement;

(iv) Reimbursing TVA for the costs of procuring and installing any TVA-owned meters that are required for the deployment and operation of the Project in accordance with TVA’s “Metering Requirements” as such term is defined in the Guidelines;

(v) Providing such metering and communication devices for the Project as may be required by TVA to ensure its operational reliability under its operating guidelines, to provide TVA with unrestricted remote access to metering data at all times, and physical access to metering facilities for the purpose of confirming remotely accessed data, all in accordance with TVA’s published interconnection procedures and the Interconnection Agreement;

(vi) Complying with TVA interconnection procedures and standards in effect at the time of interconnection; and

(vii) Executing any necessary agreements and other necessary documentation as TVA may require pursuant to the Guidelines relating to the metering, operation and maintenance of the Project.

Seller shall be responsible for fully discharging each of these obligations on behalf of LPC. Except as expressly set forth in Section 17.24 and further provided, however, that Seller may Terminate this Agreement without penalty or recourse by LPC if TVA requirements in this Section 17.24 change during the term of this Agreement.

(a) Seller does not assume any other obligations, liabilities, or duties of LPC under the Guidelines or under any Power Supply Expanded Flexibility Agreement or similar agreement between TVA and LPC related to LPC’s purchase of energy from TVA or LPC’s participation in any TVA program permitting LPC’s procurement of energy from sources other than TVA.

(b) Notwithstanding any other provision in this Agreement to the contrary, in the event of a conflict between the terms of this Agreement and the foregoing requirements under the Guidelines, the Guidelines will control as necessary to resolve the conflict, except (i) where the Guidelines incorporate by reference the Power Supply Expanded Flexibility Agreement or similar agreement between TVA and LPC, it being understood that Seller is not party to, and has not been provided with, such agreement, and in which case this Agreement shall control over the Guidelines, and (ii) where such conflict relates to the interconnection or parallel operation of the Project, in which case TVA’s published interconnection procedures and the Interconnection Agreement shall control; and (iii) if any TVA requirements espoused in this Section 17.24 change during the Term of the Agreement, Seller may, at its sole discretion, Terminate this agreement without penalty or recourse by the LPC

Section 17.25. TVA Waiver. Solely for the purposes of this Agreement, TVA waives Seller’s obligations regarding Continuous Reactive Power Support under the Participation Requirements section of the Guidelines.

IN WITNESS WHEREOF, the Parties have caused this Agreement to be executed as of the date first above written.

INTERNATIONAL PAPER COMPANY

By: \_\_\_\_\_

Name: Aimee Gregg

Title: Senior Vice President Supply Chain IT

IP Legal Review

By: \_\_\_\_\_

KNOXVILLE UTILITIES BOARD

By: \_\_\_\_\_

Name: Gabriel Bolas

Title: President and CEO

## EXHIBITS

Exhibit A	Contract Price
Exhibit B	Insurance
Exhibit C	Legally Required Clauses
Exhibit D-1	Project Description
Exhibit E	Current TVA Guidelines
Exhibit F	Renewable Energy Credit Confirmation
Exhibit G	Curtailement Procedures

## EXHIBIT A

### CONTRACT PRICE

In accordance with Section 4.5 and the Term Sheet executed on August 13<sup>th</sup>, 2024, the contract pricing will be as follows:

- **Seller Percentage:** Ninety percent (90%) of LPC's reimbursement under the TVA Power Supply Flexibility Program, as defined in LPC's "Flexibility Option Purchase Power Agreement" (FOPPA) with TVA
- **Price Floor:** The greater of 90%, as defined above, or \$58.50/MWh, with the only exception to this Price Floor being as follows:
  - In any event, the pricing that LPC pays to seller for the project shall not exceed the amount reimbursed to LPC under the TVA FOPPA. LPC shall notify Seller as soon as possible once receiving any indication that FOPPA reimbursement may drop below the Price Floor. In such event, Seller may curtail generation as needed to account for lost reimbursements.
- **Price Ceiling:** The lower of 90%, as defined above, or \$85.00/MWh

## EXHIBIT B

### INSURANCE

A. Seller Insurance Coverages. Seller shall maintain or cause to be maintained the types of insurance coverages described in this Part A, provided that Seller shall be required to maintain the insurance coverages described in this Part A only to the extent that such coverages are available on Commercially Reasonable terms in the commercial insurance markets. All insurance coverages described herein shall be placed with Acceptable Insurance Companies. An “Acceptable Insurance Company” means an insurance company that, at the applicable time, is legally permitted to write the applicable insurance coverage and that (i) has a Credit Rating of A- or better from Standard & Poor’s at such time or (ii) has an insurance company rating of A- or better from A.M. Best at such time. The Parties agree that Seller may self insure in accordance with Applicable law.

1. Workers’ Compensation Insurance. Seller shall maintain or cause to be maintained workers’ compensation insurance in compliance with Applicable Law. Such required workers compensation coverage shall also include Employer’s Liability with limits of no less than \$500,000 and shall also include a waiver of subrogation in favor of LPC.

2. Commercial General Liability Insurance. Seller shall maintain or cause to be maintained commercial general liability insurance, including coverage for bodily injury, property damage, personal injury, death, products/completed operations, premises/operations, explosion, collapse and underground hazards, broad form property damage and blanket contractual liability for written contracts, with primary and non-contributory coverage limits of not less than \$1,000,000 per occurrence and an annual aggregate limit of not less than \$2,000,000.

3. Automobile Liability Insurance. Seller shall maintain or cause to be maintained automobile liability insurance for owned, non-owned and hired automobiles for both bodily injury and property damage and containing appropriate no-fault insurance provisions or other endorsements in accordance with Applicable Law, with a combined single limit of not less than \$1,000,000 with respect to bodily injury, property damage or death.

4. Umbrella Liability Insurance: Seller shall maintain an umbrella liability with a minimum limit of \$1,000,000 excess of the insurances required in 2 and 3 above.

5. All-Risk Property Insurance. Seller shall maintain or cause to be maintained all-risk property coverage for the Project with Commercially Reasonable limits, sub-limits and deductibles.

B. Seller Insurance General Terms. To the extent available on Commercially Reasonable terms in the commercial insurance markets:

1. Evidence of Coverage. Seller shall deliver to LPC certificates or other evidence of all insurance policies maintained (or caused to be maintained) by Seller upon request.

2. Additional Insureds. LPC shall be named as an additional insured on all liability policies required under this Exhibit.

3. Termination of Coverage. Seller shall provide LPC prior written notice of any cancellation or non-renewal of any insurance policy required to be maintained (or caused to be maintained) by Seller, and which insurance policy is not replaced, pursuant to this Exhibit B.

C. Self-Insurance. Notwithstanding the foregoing, Seller may self-insure to meet the minimum insurance requirements of this Exhibit B to the extent it maintains a self-insurance program, provided that Seller’s senior secured debt meets the ratings requirements applicable to a Qualified Bank and its self-insurance program meets the minimum insurance requirements of this Exhibit B. For any period of time that

Seller's senior secured debt is unrated by Standard & Poor's or is rated at less than investment grade by Standard & Poor's, Seller shall comply with the insurance requirements applicable to it under this Exhibit B. In the event that Seller is permitted to self-insure pursuant to this section, it shall notify LPC that it meets the requirements to self-insure and that its self-insurance program meets the minimum insurance requirements in a manner consistent with that specified in this Exhibit B. LPC may request a "confirmation of compliance" to demonstrate Seller compliance with Exhibit B.



## EXHIBIT C

### LEGALLY REQUIRED CLAUSES

The Parties shall comply with all Applicable Law. To the extent required by Applicable Law, the following clauses shall apply to the Parties' performance of the Agreement to which this Exhibit C is attached. References in this Exhibit C to "contract" refer to the Agreement to which Exhibit C is attached.

#### AFFIRMATIVE ACTION AND EQUAL OPPORTUNITY

**Provider's Compliance.** LPC agrees to abide by the provisions of the following, as applicable, which are incorporated herein by reference: (a) Equal Employment Opportunity, Employment of Women, Minorities, Veterans and Individuals with Disabilities; 41 CFR 60-741.44, 60-300.44, and Executive Order 11246; and (b) Employment Eligibility Verification (E-Verify); Executive Order 13465 for federal contracts in excess of \$150,000 and subcontracts in excess of \$3000; and (c) Notification of Employee Rights under Federal Law 29 CFR Part 471, Appendix A to Subpart A of Executive Order 13496; and (d) The Trafficking Victims Protection Act of 2000 (Public Law 106-386) as amended. **Unless exempt, Seller and LPC shall abide by the requirements of 41 CFR §§ 60-1.4(a), 60-300.5(a) and 60-741.5(a).** These regulations prohibit discrimination against qualified individuals based on their status as protected veterans or individuals with disabilities, and prohibit discrimination against all individuals based on their race, color, religion, sex, sexual orientation, gender identity, or national origin. Moreover, these regulations require that covered prime contractors and subcontractors take affirmative action to employ and advance in employment individuals without regard to race, color, religion, sex, sexual orientation, gender identity, national origin, protected veteran status, or disability. In addition, Seller will not discharge or in any other manner discriminate against any employee or applicant for employment because such employee or applicant has inquired about, discussed, or disclosed the compensation of the employee or applicant or another employee or applicant.

#### BYRD RIDER

Lobbying. This contract is subject to the requirements of Public Law No. 101-121 (codified at 31 U.S.C. § 1352), which prohibits certain lobbying activities and requires disclosure of certain others, and to TVA's implementing regulations published at 55 Fed. Reg. 6736 (codified at 18 C.F.R. § 1315).

#### A. Prohibition, Certification, and Disclosure

- (1) Appropriated Funds. Section 319 of Public Law No. 101-121 provides that none of the funds appropriated by any act of Congress may be expended by the recipient of a Federal contract, grant, loan, or cooperative agreement to pay any person for influencing or attempting to influence an officer or employee of any agency, a member of Congress, an officer or employee of Congress, or an employee of a member of Congress in connection with: (a) the awarding of any Federal contract; (b) the making of any Federal grant; (c) the making of any Federal loan; (d) the entering into of any cooperative agreement; or (e) the extension, continuation, renewal, amendment, or modification of any Federal contract, grant, loan, or cooperative agreement.
- (2) Certification. Seller, by signing this contract, certifies in accordance with the "Certification for Contracts, Grants, Loans, and Cooperative Agreements," set forth below ("Certification"), that it has not violated the foregoing prohibition.
- (3) Other Than Appropriated Funds. Except as provided in subsection D, below, if Seller has paid or will pay any funds other than Federal appropriated funds to any person for influencing or attempting to influence an officer or employee of any agency, a member of Congress, an officer or employee of Congress, or an employee of a member of Congress in connection with this contract, Seller shall complete and submit to TVA Standard Form-LLL, "Disclosure of

Lobbying Activities," in accordance with its instructions. (Copies of Standard Form-LLL may be obtained from the TVA representative for this contract.) The requirements of this subsection A(3) shall not apply to payments of reasonable compensation to regularly employed officers or employees. The term "regularly employed," with respect to an officer or employee of a person requesting or receiving a contract, means an officer or employee who is employed by such person for at least 130 working days within one year immediately preceding the date of the submission that initiates TVA's consideration of such person for receipt of such contract.

- B. Updating. At the end of each calendar quarter in which there occurs any event that materially affects the accuracy of the information contained in the Certification or, if applicable, Standard Form-LLL, Seller shall file with TVA an initial or new Standard Form-LLL with such new information or modifications as are necessary to correct any inaccuracies in the information originally declared and certified.
- C. Subcontractors. Seller shall include or cause to be included the form of the Certification in any subcontract exceeding \$100,000 at any tier. Seller shall promptly file with TVA each Standard Form-LLL provided by a subcontractor.
- D. Exceptions. The prohibition described in subsection A(1) above and the disclosure requirements in subsection A(3) do not apply in the case of (1) a payment of reasonable compensation made to an officer or employee of Seller to the extent that the payment is for agency and legislative liaison activities not directly related to a Federal action referred to in subsection A; or (2) any reasonable payment to a person, or any payment or reasonable compensation to an officer or employee of Seller, if the payment is for professional or technical services rendered directly in the preparation or negotiation of this Agreement.
- E. Definitions. Terms not defined herein shall have the meanings ascribed to them in Public Law No. 101-121 and TVA's implementing regulations.
- F. Penalties. (1) Any person who makes an expenditure prohibited by Public Law No. 101-121 shall be subject to a civil penalty of not less than \$10,000 and not more than \$100,000 for each such expenditure; and (2) any person who fails to file or amend a certification required under subsection A(2) above or a disclosure required to be filed or amended under subsection A(3) above shall be subject to a civil penalty of not less than \$10,000 and not more than \$100,000 and to such other remedies as may apply for each such failure.

BYRD RIDER EXHIBIT

Certification for Contracts, Grants,  
Loans, and Cooperative Agreements

The undersigned certifies, to the best of his or her knowledge and belief, that:

- (1) No Federal appropriated funds have been paid or will be paid by or on behalf of the undersigned to any person for influencing or attempting to influence an officer or employee of any agency, a member of Congress, an officer or employee of Congress, or an employee of a member of Congress in connection with the awarding of any Federal contract, the making of any Federal grant, the making of any Federal loan, the entering into of any cooperative agreement, and the extension, continuation, renewal, amendment, or modification of any Federal contract, grant, loan, or cooperative agreement.
- (2) If any funds other than Federal appropriated funds have been paid or will be paid to any person for influencing or attempting to influence an officer or employee of any agency, a member of Congress, an officer or employee of Congress, or an employee of a member of Congress in connection with this Federal contract, grant, loan, or cooperative agreement, the undersigned shall complete and submit Standard Form-LLL, "Disclosure of Lobbying Activities," in accordance with its instructions.
- (3) The undersigned shall require that the language of this certification be included in the award documents for all subawards at all tiers (including subcontracts, subgrants, and contracts under grants, loans, and cooperative agreements) and that all subrecipients shall certify and disclose accordingly.

This certification is a material representation of fact upon which reliance was placed when this transaction was made or entered into. Submission of this certification is a prerequisite for making or entering into this transaction imposed by 31 U.S.C. 1352. Any person who fails to file the required certification shall be subject to a civil penalty of not less than \$10,000 and not more than \$100,000 for each such failure.

## EXHIBIT D-1

### **PROJECT DESCRIPTION**

The Project comprises the Biomass Asset and associated equipment and facilities, together known as COLUMBUS CELLULOSE FIBERS COGENERATION FACILITY, located in LOWNDES COUNTY, MISSISSIPPI, including the real property, fixtures, and land rights associated with the facility. The Project is located at Latitude N33.35879 degrees, Longitude W88.45996 degrees, in Section 7, Township 17 North Range 18 East, Lowndes County, Mississippi.

The Biomass Asset is a 45 MW generation facility that uses the heat generated by Biomass Co-firing or the combustion of Qualified Biomass to generate electricity.

**Qualified Biomass** means a solid, liquid, or gaseous form of Renewable Biomass that is produced from the following fuels in a manner that complies with all applicable Laws and Regulations:

- a. All wood waste including “black liquor” from pulp and paper processing, mill residues, industrial waste wood, and wasted wood from woodworking or wood processing, and woody biomass such as hog fuel or bark, so long as the wood is not chemically treated or coated;
- b. All agricultural crops or waste;
- c. All animal and other organic waste;
- d. All energy crops; and
- e. Landfill gas and wastewater methane.

**Biomass Co-firing** of eligible forms of Qualified Biomass with non-renewable fuel is permitted if all of the following conditions are met:

- a. The Qualified Biomass is separately metered, and Operator verifies, in a method approved by TVA, that the Qualified Biomass portion is converted to Energy Output;
- b. At least 50% of the heat input is from Qualified Biomass;
- c. The Biomass Asset is in compliance with all Applicable Laws regarding emissions; and
- d. emissions from the non-Qualified Biomass portion do not exceed TVA’s average annual emissions rates as reported in eGrid (<http://www.epa.gov/cleanenergy-resources/egrid/index.html>).

The Biomass Asset at all times will generate and deliver electric power and energy exclusively from the combustion of Qualified Biomass or from Biomass Co-firing. Unless approved in advance by TVA in writing, the Biomass Asset will not generate or deliver electric power or energy by means of non-biomass combustion generation technologies; provided, however, that LPC recognizes and affirms that Seller may generate electric power and energy from the same Biomass Assets for its own station load, but will apportion only Qualified Biomass fuels as defined in this Exhibit D-1 to LPCs generation.

The Project will be interconnected at the “Delivery Point,” which is WEYERHAEUSER 161-kVA SWITCHYARD and the settlement point will be the TVA LOWNDES TRANSMISSION SYSTEM.

### **Contract Output and Term Schedule**

The maximum Contract Output under this Agreement will be as set forth in the tabulation below.

<b>Date</b>	<b>Contract Output (MW)</b>
Effective Date - 1/30/2025	32.674
1/31/2025 - 12/31/2026	24.674

12/1/2026 – 6/29/2028	16.674
-----------------------	--------

TVA may, in its sole discretion, adjust the tabulation set forth above in the event LPC enters into additional projects or initial delivery dates for projects change under TVA's Generation Flexibility Program.

In the event LPC deploys additional Energy Resources or the initial delivery dates of Energy Resources change under TVA's Generation Flexibility Program, LPC may request an adjustment to the tabulation set forth above by submitting to TVA, at least 45 days prior to the desired adjustment date, a request detailing LPC's desired adjustments to the tabulation set forth above. TVA will review the request, and, in its reasonable discretion, approve or deny said request. If TVA denies LPC's request, it will provide LPC a response detailing its reasoning. Nothing in this section authorizes LPC to violate any terms under the Enhanced Flexibility Agreement or the Enhanced Flexibility Guidelines attached thereto.

In the event LPC is requesting an increase or extension of contract output, LPC will request approval from Seller prior to submitting an adjustment request to TVA. LPC will promptly communicate TVA approved changes to Seller.

Any delivered energy and Attributes delivered to LPC from Seller shall not exceed KUBs Flexibility Capacity Allocation as estimated by LPC.

Whether the Project satisfies the Contract Output requirement will be determined by measuring the maximum instantaneous AC power output of the Project, using the Metering Equipment, at the high side of the Delivery Point transformer, net of any station service and transmission and distribution losses.

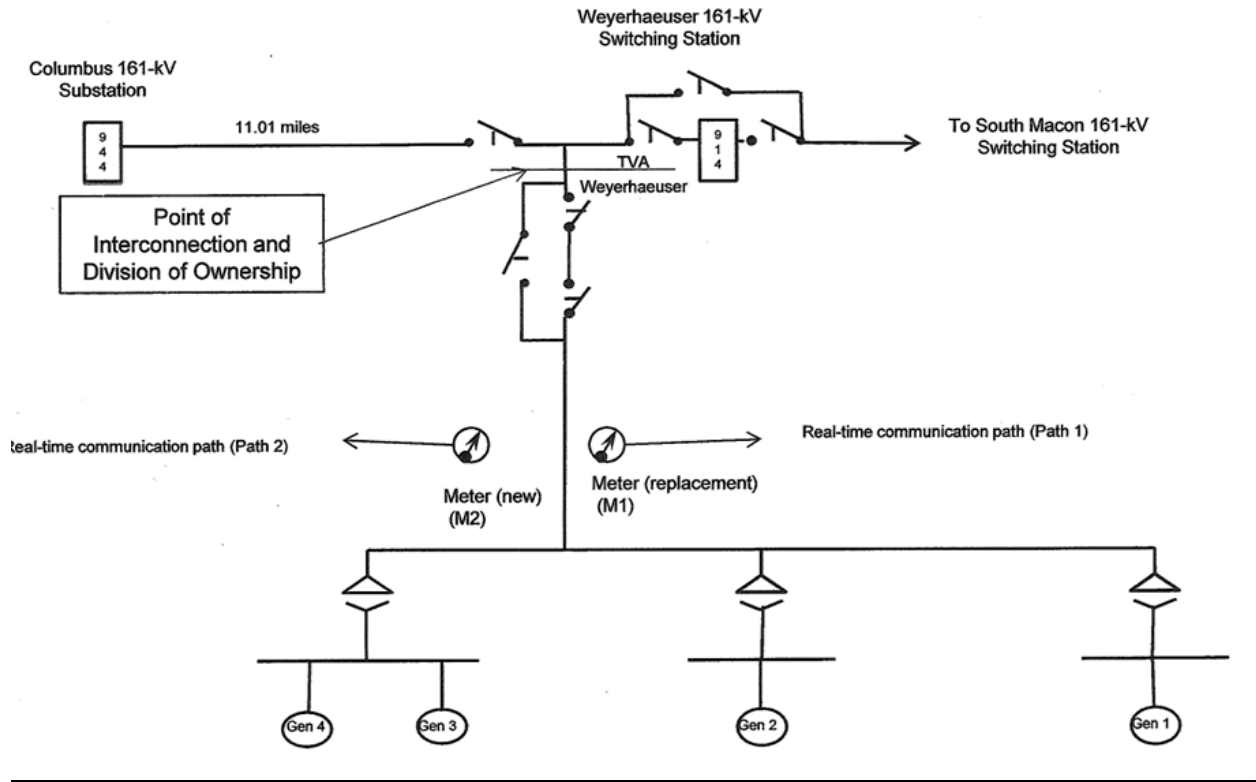

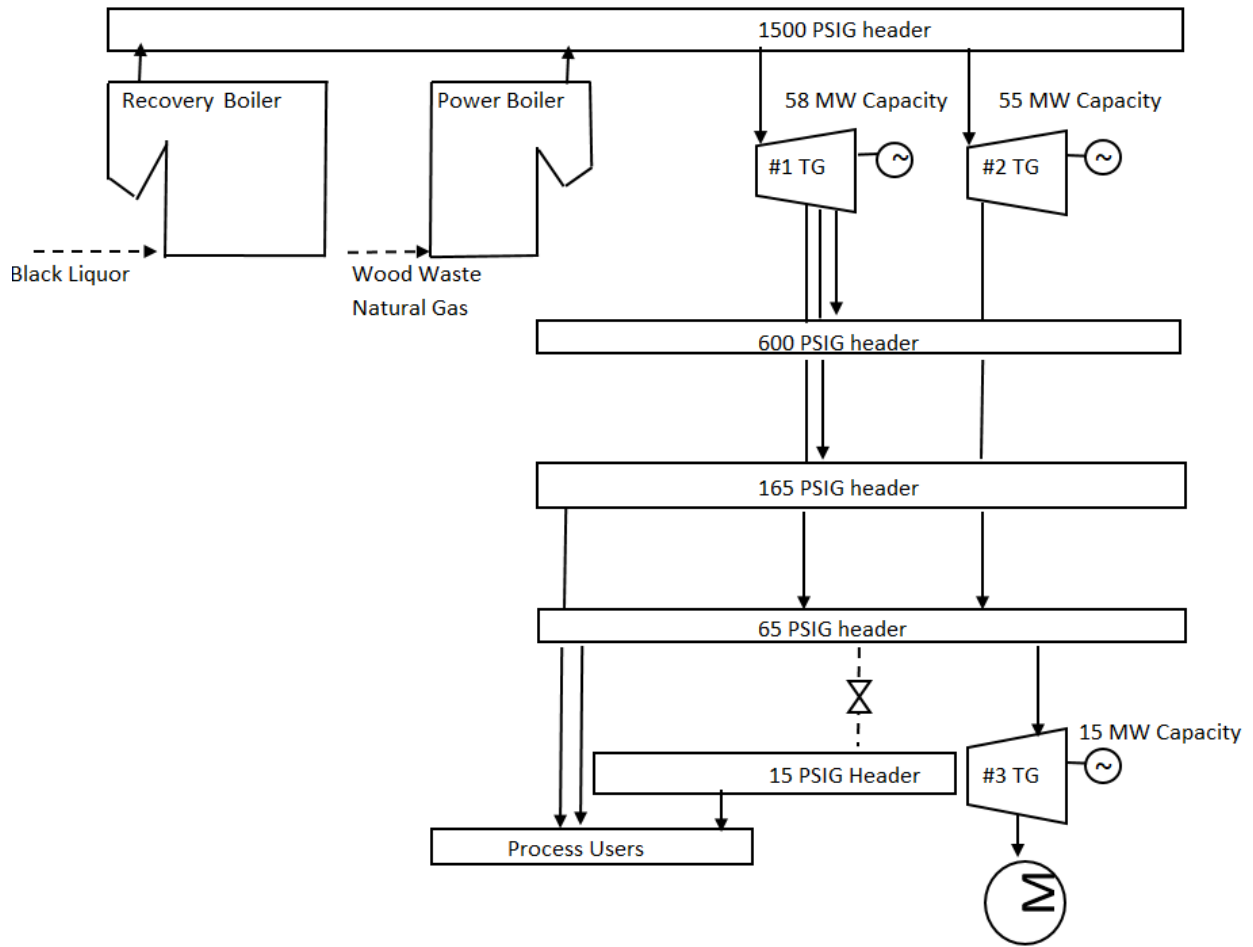

**EXHIBIT E**  
**CURRENT TVA GUIDELINES**

See attached.



## EXHIBIT F

### RENEWABLE ENERGY CERTIFICATE CONFIRMATION

This Renewable Energy Certificate Confirmation (the “Confirmation”), dated December \_\_\_\_\_, 2024 (the “Effective Date”), is entered into by and between \_\_\_\_\_ (“Counterparty” or “Buyer”) and International Paper Company (“IPC”) and is made a part of the Power Purchase Agreement between Company and Counterparty dated as of December \_\_\_\_, 2024 (as amended, supplemented, or otherwise modified, the “Master Agreement”). This Confirmation is governed by, and is subject to, the Master Agreement. Terms capitalized but not defined in this Confirmation are defined in the Master Agreement. Counterparty and IPC are sometimes referred to in this Confirmation together as the “Parties” and individually as a “Party.”

This Confirmation memorializes the Parties’ understanding concerning the transfer obligation for RECs described further below on and after the Effective Date and under the terms and conditions set forth in the Master Agreement. In the event of any conflict or inconsistency among the provisions of the Master Agreement and this Confirmation, the following order of precedence shall apply: (i) the Master Agreement; then (ii) this Confirmation.

Commercial Terms: The specific terms and conditions of the transaction are described in the Agreement and set forth herein below.

Trade Date:	Effective Date
Buyer:	[same as Buyer above]
Seller:	International Paper Company
REC Product:	Voluntary Biomass RECs, which means as of the date on which the RECs are transferred or retired, a REC evidenced by the applicable REC Tracking System and associated with one (1) MWh of energy generated by a renewable resource as defined by the Applicable Program.
Renewable Fuel Source:	Biomass: Black Liquor (BLQ) or Woody Waste (BWW)
Vintage Year/Reporting Year, as applicable (“VY” or “RY”)	VY 2024 (January 1, 2024 – December 31, 2024) VY 2025 (January 1, 2025 – December 31, 2025) VY 2026 (January 1, 2026 – December 31, 2026) VY 2027 (January 1, 2027 – December 31, 2027) VY 2028 (January 1, 2028 – December 31, 2028)
Contract Quantity:	See Master Agreement. The REC quantity to be delivered will be based on the invoiced energy sales in MWh for the delivery period through the term of the agreement. Per REC registry, RECs are generated based on whole MWh of energy. No REC will be delivered for partial MWh for the period if a partial MWh is shown on the invoiced as delivery quantity of energy.
Unit price:	See Master Agreement. The REC unit is part of the delivery of energy. There is no additional cost per REC associated with the Master Agreement sale.
Delivery:	RECs will be delivered to Counterparty following receipt of payment for energy delivered for the period. This delivery will be within 15 business days following payment. Delivery through retirement and delivery of retirement certification from REC tracking system via email to Buyer designated distribution.
Delivery Obligation (Firm/Unit Contingent)	Unit Contingent
Applicable Region:	Generated in the Tennessee Valley Authority generation and distribution region
Applicable Program:	Voluntary
REC Tracking System:	M-RETS

IN WITNESS WHEREOF, the Parties have caused this REC Confirmation to be executed as of the date first above written.

INTERNATIONAL PAPER COMPANY

By: \_\_\_\_\_

Name: Aimee Gregg

Title: Senior Vice President Supply Chain IT

IP Legal Review

By: \_\_\_\_\_

KNOXVILLE UTILITIES BOARD

By: \_\_\_\_\_

Name: Gabriel Bolas

Title: President and CEO

**EXHIBIT G**

**CURTAILMENT PROCEDURES**

**Curtailment Rights**

Pursuant to Power Purchase Agreement (PPA) and Flexibility Option Power Purchase Agreement (FOPPA), TVA will have the right to order Operator (International Paper) to Curtail Energy Output deliveries from the Project.

**Curtailment Obligations**

Operator must cease all Energy Output from the Project or disconnect from the TVA grid within 30 minutes after TVA or LPC provides notification that an emergency condition exists. TVA or LPC will promptly notify Operator when the emergency condition has ended, at which time Operator may resume Energy Output at the Project or reconnect and synchronize to the grid.

In the event of non-emergency curtailments, Operator will comply with the 30 minutes notice to the best of its ability; however, Operator may exceed such notice period to protect the integrity, safety, and reliability of the facility in the event of a non-emergency curtailment.

**Notice to Curtail**

The designated Curtailment notice method is verbally, by telephone. Such verbal notices will be given to the Curtailment notice phone number(s) provided below. TVA or LPC will attempt to reach each of the Curtailment notice phone number(s) provided below. If no one is reached at the phone number(s) provided, TVA or LPC may (without obligation) attempt to call the number(s) until one acknowledges the notice or the additional calling attempts have been exhausted.

Curtailment notice phone number(s)	662-243-4358 662-242-5403 662-243-4701
------------------------------------	--

TVA or LPC may, but is not obligated to, provide additional Curtailment notifications to Company through additional avenues that are not currently the notice method designated above in this subsection, such as text message, voicemail, or email. Such notices are provided for convenience only and are provided by TVA or LPC without obligation.

**Other Notices**

For receipt of written notices pursuant to this Exhibit, Operator has designated the email address(es) below:

steven.holley@ipaper.com	ian.spurr@ipaper.com	denise.martin@ipaper.com
natalie.jolley@ipaper.com		

**POWER PURCHASE AGREEMENT**

**BETWEEN**

**TENNESSEE VALLEY AUTHORITY**

**And**

**KNOXVILLE UTILITIES BOARD**

**POWER PURCHASE AGREEMENT**

**BETWEEN**

**TENNESSEE VALLEY AUTHORITY**

**And**

**KNOXVILLE UTILITIES BOARD**

---

THIS AGREEMENT, is made and entered into this \_\_\_ day of December, 2024 (“Effective Date”), by and between TENNESSEE VALLEY AUTHORITY, a corporate agency and instrumentality of the United States of America created by and existing under and by virtue of the Tennessee Valley Authority Act of 1933, as amended, hereinafter called “TVA,” and KNOXVILLE UTILITIES BOARD, hereinafter called “Seller,” collectively “the Parties,” and each individually a “Party.”

**RECITALS**

WHEREAS, TVA is engaged in the generation, transmission, and supply of electric power and energy in the Tennessee Valley region;

WHEREAS, Seller purchases its power requirements from TVA for resale under contract number TV-75110A, effective July 1, 1988, as amended (“Power Contract”);

The parties entered into the Long-Term Agreement, Supplement 114 to the Power Contract, effective March 12, 2020 (“LTA”), covering arrangements to increase the length of and strengthen the contractual relationship of the parties to help ensure the long-term success of the public power model;

WHEREAS the parties previously entered into a Power Supply Expanded Flexibility Agreement, Contract No. TV-75110A, Supp. No. 130, effective September 29, 2023, as amended (“Expanded Flexibility Agreement”), to expand the opportunities under which Seller may deploy energy resources to produce its own power and further strengthen the public power model;

WHEREAS, pursuant to a power purchase agreement (the “Frontend PPA”) entered into or to be entered into between Seller and International Paper (“Operator”), Operator is operating a biomass electric generation facility known as COLUMBUS CELLULOSE FIBERS COGENERATION FACILITY, located in LOWNDES COUNTY, MISSISSIPPI (the “Project”) which is interconnected at the WEYERHAEUSER 161-kVA SWITCHYARD.

WHEREAS, pursuant to the Frontend PPA, Seller will acquire from Operator the energy output, environmental attributes, and other project attributes (as those terms are similarly defined in this Agreement) generated by the Project;

WHEREAS, Seller desires to sell to TVA, and TVA desires to purchase from Seller, the amount of Energy Output and Other Project Attributes from the Project, subject to the terms and conditions herein;

NOW, THEREFORE, in consideration of the promises and the representations, warranties, covenants, and conditions hereinafter set forth, and for other good and valuable consideration, the receipt and sufficiency of which are hereby acknowledged, the Parties, intending to be legally bound, hereby agree as follows:

## ARTICLE I: DEFINITIONS

1.1 “Affiliate” means, with respect to any Person, any other Person (other than an individual) that, directly or indirectly, through one or more intermediaries, controls, or is controlled by, or is under common control with, such Person. For this purpose, “control” means the direct or indirect ownership of fifty percent (50%) or more of the outstanding capital stock or other equity interests having ordinary voting power.

1.2 “Ancillary Services” means those services that are necessary to support the transmission of capacity and energy from resources to loads while maintaining reliable operation of TVA’s transmission system in accordance with Good Utility Practice. For the avoidance of doubt, Ancillary Services do not include Continuous Reactive Power Support.

1.3 “Applicable Law” means all Federal, state, local, or municipal laws, statutes, codes, acts, treaties, ordinances, orders, judgments, writs, decrees, injunctions, rules, regulations, governmental approvals, licenses, permits, directives, and requirements of all regulatory, judicial, and other Governmental Authorities that legally apply in the particular situation in question.

1.4 “Bankrupt” means with respect to any Person, such Person (i) files a petition or otherwise commences, authorizes, or acquiesces in the commencement of a proceeding or cause of action under any bankruptcy, insolvency, reorganization, or similar law, or has any such petition filed or commenced against it, (ii) makes an assignment or any general arrangement for the benefit of creditors, (iii) otherwise becomes bankrupt or insolvent (however evidenced), (iv) has a liquidator, administrator, receiver, trustee, conservator, or similar official appointed with respect to it or any substantial portion of its property or assets, or (v) is generally unable to pay its debts as they fall due.

1.5 “Business Day” means any day except a Saturday, Sunday, or a federal holiday observed by TVA. Such holidays currently are New Year’s Day, Martin Luther King, Jr. Day, Presidents Day, Memorial Day, Juneteenth National Independence Day, Independence Day, Labor Day, Columbus Day, Veterans Day, Thanksgiving Day, and Christmas Day. A Business Day shall begin at 8:00 a.m. and end at 5:00 p.m. CPT.

1.6 “Capacity Attributes” means any current or future defined characteristic, certificate, tag, credit, or accounting construct associated with the amount of power that the Project can generate at a particular moment and that can be purchased and sold under Applicable Law and market rules or other transactional requirements applicable in the region where the Project is located. Capacity Attributes do not include any credits or certificates falling within the definition of Environmental Attributes.

1.7 “Cash” means money denominated in United States Dollars.

1.8 “Claiming Party” has the meaning set forth in Section 14.1.

1.9 “Commercially Reasonable” means, with respect to any action required to be made, attempted, or taken by TVA or Seller under this Agreement, such efforts as a reasonably prudent business would undertake for the protection of its own interest under the conditions affecting such action, including the amount of notice of the need to take such action, the duration and type of action, the competitive environment in which such action occurs, and the risk to the Party required to take such action. With respect to price or cost, Commercially Reasonable means the price or cost obtained or reasonably expected to be obtainable given good faith efforts in a competitive business environment. The price or cost obtained need not necessarily be the lowest or highest (as the case may be) price or cost available at the time so long as such price or cost can be demonstrated to have been reasonably obtained through good faith efforts in a competitive business environment. Commercially Reasonable efforts shall not generally require the payment of fees not otherwise contemplated under this Agreement nor the making of any material financial or other concessions as a condition to accomplishing the result contemplated.

1.10 [Reserved]

1.11 “Contract Price” has the meaning set forth in Section 4.4.

1.12 “Contract Output” (CO) is specified in Exhibit D-1.

1.13 “Costs” means, with respect to the Non-Defaulting Party: (a) brokerage fees, commissions, financing breakage fees, and other similar third-party transaction costs (including any related make-whole costs for early prepayment provisions payable to lenders, tax equity investors and other financing parties), and necessary expenses incurred by such Party in a Commercially Reasonable manner (i) as a result of the termination of this Agreement, or (ii) in entering into new arrangements that replace this Agreement, plus (b) all expenses or liabilities incurred in a Commercially Reasonable manner by, or imposed upon or claimed against the Non-Defaulting Party, in connection with the termination of this Agreement pursuant to Article VIII, or the specific Seller Event of Default described in Section 8.1.

1.14 “CPT” means Central Prevailing Time, meaning prevailing Standard Time or Daylight Saving Time in the Central Time Zone.

1.15 [Reserved]

1.16 [Reserved]

1.17 “Curtailed” means any reduction in whole or in part of energy production at the Project to maintain transmission system reliability pursuant to the instruction or other directive made or issued by TVA, any other affected transmission service provider, or any other entity with authority to direct such a reduction of energy production.

1.18 “Defaulting Party” has the meaning set forth in Section 8.1.

1.19 “Delivery Period” means (a) in the case of the first such period (Year 1), the period commencing on the Effective Date and ending on the next December 31<sup>st</sup> that is at least 365 days later, (b) in the case of each such period subsequent to the first such period (but not including the last such period), each twelve (12) calendar months commencing on the January 1<sup>st</sup> next following the end of the prior period (each a “Full Contract Year”), and (c) in the case of the last such period during the Term, the period beginning on the January 1<sup>st</sup> next preceding the final anniversary of the Effective Date and ending on such final anniversary of the Effective Date.

1.20 “Delivery Point” is the point of transmission interconnection to the TVA system, as set forth in Exhibit D-1.

1.21 [Reserved]

1.22 “Downgrade Event” means a reduction in the credit rating of a Qualified Bank.

1.23 “Early Termination Date” has the meaning set forth in Section 8.3.

1.24 “Effective Date” has the meaning set forth in the first paragraph of this Agreement.

1.25 “Electric System” means the network of electric transmission or distribution facilities, equipment, and other devices owned and/or controlled by TVA to which the Project interconnects.

1.26 “Energy Output” means the amount of energy, generated by the Project and delivered to the Delivery Point, as metered by the Metering Equipment, net of internal, parasitic or auxiliary load, and shall not exceed the Contract Output over any applicable metering interval.

1.27 [Reserved]

1.28 “Environmental Attributes” means any and all aspects, credits, certificates, claims, characteristics, or benefits associated with the use of a quantity of energy generated by a renewable energy resource and that is capable of being measured, verified, or calculated. Environmental Attributes do not include: (a) federal, state, or local tax credits or other similar incentives; or (b) any avoided adverse wildlife or environmental impacts or avoided emissions of pollutants to the environment.

1.29 “Event of Default” has the meaning set forth in Section 8.1.

1.30 “Force Majeure Event” means the following or similar (in nature and severity) event(s): act of God, act of civil or military authority, war, terrorist attacks, riot, insurrection, unusually severe weather, blockades, embargoes, sabotage, pandemics, or epidemics, in any of the foregoing cases, which: (i) are outside the control and without fault or negligence of a Party claiming that such event has occurred, and (ii) directly and actually cause delay(s) in or prevent a Party’s performance or completion of critical work. Notwithstanding anything herein to the contrary, (i) a lack of or reduction in the amount of sunshine, (ii) economic hardship, (iii) any failure to secure or maintain permits, except to the extent caused by a separate Force Majeure Event, and (iv) inability to obtain or maintain any expected tax benefits are not (separately or together) Force Majeure Event(s).

1.31 “Forced Project Outage” means any reduction or cessation of energy generation by the Project involving the shutdown of, and physical unavailability of generation from, Project facilities caused by any condition at the Project (as opposed to a Curtailment), other than Project Maintenance or Force Majeure Event(s).

1.32 “Full Contract Year” has the meaning set forth in the definition of “Delivery Period.”

1.33 “Gains” means with respect to a Non-Defaulting Party, an amount equal to the present value of the economic benefit to it, if any (exclusive of Costs), that directly results from the termination of this Agreement for the remaining term of this Agreement, determined in a Commercially Reasonable manner. Factors used in determining economic benefit may include reference to information either available to it internally or supplied by one or more non-Affiliate third parties, including quotations (either firm or indicative) of relevant rates, prices, yields, yield curves, volatilities, spreads, or other relevant market data in the relevant markets, comparable transactions, forward price curves based on economic analysis of the relevant markets, or settlement prices for comparable transactions at liquid trading hubs in the relevant markets, all of which should be calculated for the remaining term of this Agreement.

1.34 “Good Utility Practice” means any of the practices, methods, and acts engaged in or adopted by a significant portion of the electric utility industry during the relevant time period, or practices, methods, and acts that, in the exercise of reasonable judgment in light of the facts known at the time the decision was made, could have been expected to accomplish the desired result at reasonable cost consistent with good business practices, reliability, safety, and expedition. Good Utility Practice is not intended to be limited to any particular set of optimum practices, methods, or acts to the exclusion of all others, but rather is intended to include a spectrum of acceptable practices, methods, or acts generally accepted in the electric utility industry.

1.35 “Governmental Authority” means any nation, government, state, or other political subdivision thereof, whether foreign or domestic, including any municipality, township, and county, and any entity exercising executive, legislative, judicial, regulatory, or administrative functions of or pertaining to government, including any corporation, or any entity owned or controlled by any of the foregoing. The term “Governmental Authority” shall not include TVA, Seller, or Seller when acting in a non-governmental capacity.

1.36 “Governmental Charges” has the meaning set forth in Section 13.2.



1.37 [Reserved]

1.38 [Reserved]

1.39 "Interconnection Agreement" means an agreement entered into between interconnection requestor and TVA to provide for the interconnection of the Project to TVA's electric system.

1.40 "kW" means kilowatt or kilowatts, alternating current.

1.41 "kWh" means kilowatt-hour or kilowatt-hours.

1.42 "Letter of Credit" means an irrevocable standby letter of credit from a Qualified Bank in substantially the form attached hereto as Attachment 1 to Exhibit A, naming TVA as the beneficiary.

1.43 "Losses" means with respect to a Non-Defaulting Party, an amount equal to the present value of the economic loss to it, if any (exclusive of Costs) resulting from the termination of this Agreement for the remaining term of this Agreement, determined in a Commercially Reasonable manner. Factors used in determining the loss of economic benefit may include reference to information either available to it internally or supplied by one or more non-Affiliate third parties including quotations (either firm or indicative) of relevant rates, prices, yields, yield curves, volatilities, spreads, or other relevant market data in the relevant markets, comparable transactions, forward price curves based on economic analysis of the relevant markets, or settlement prices for comparable transactions at liquid trading hubs in the relevant markets, all of which should be calculated for the remaining term of this Agreement. If Seller loses or is required to recapture any tax benefits with respect to the Project because of a breach by TVA, Losses shall include, calculated on an after-tax basis, the amount of such lost or recaptured tax benefits.

1.44 "Material Credit Event" means any event that results in Seller's failure to meet the Performance Assurance Requirements. If Seller has provided or caused to be provided a Letter of Credit in satisfaction of its Performance Assurance Requirements, then any of the following shall be deemed to be a Material Credit Event: (a) a representation or warranty made by a Qualified Bank is false or misleading in any material respect at any point during the term of this Agreement with regard to the Qualified Bank's; (b) the failure of an obligation in any Letter of Credit made in connection with this Agreement and such failure is not remedied within ten (10) calendar days after written notice; (c) a Downgrade Event has occurred; (d) a Qualified Bank becomes Bankrupt or its ownership or control is assumed by the Federal Deposit Insurance Corporation; (e) the failure of the Letter of Credit to be in full force and effect or extended for purposes of this Agreement (other than in accordance with its terms) prior to the satisfaction of all of Seller's obligations under this Agreement without TVA's written consent; or (f) the Qualified Bank repudiates, disaffirms, disclaims, or rejects, in whole or in part, or challenges the validity of, its Letter or Credit.

1.45 "Metering Equipment" has the meaning set forth in Section 5.1.

1.46 "Month" means a calendar month commencing at 00:00 CPT on the first calendar day of such month and ending at 24:00 CPT on the last calendar day of such month.

1.47 "Moody's" means Moody's Investors Service, Inc. or its successor.

1.48 "MW" means megawatt or megawatts, alternating current.

1.49 "MWh" means megawatt-hour or megawatt-hours.

1.50 "Non-Defaulting Party" has the meaning set forth in Section 8.3.

1.51 "Operator" has the meaning set forth in the recitals.

- 1.52 "Other Project Attributes" means, collectively, Capacity Attributes, and Ancillary Services.
- 1.53 "Parties" means both TVA and Seller.
- 1.54 "Party" means either TVA or Seller, as applicable.
- 1.55 "Performance Assurance" means collateral in the form of Cash or Letter(s) of Credit from Qualified Bank(s), in the amounts indicated in Exhibit A, which shall secure Seller's payment obligations under this Agreement.
- 1.56 "Performance Assurance Requirements" means Seller's provision and maintenance of the applicable Performance Assurance, or causing such Performance Assurance to be provided and maintained.
- 1.57 "Permit" means any permit, exemption, approval, license, consent, certification, authorization, concession, order, easement, or other right that is required by any applicable Governmental Authority to develop, construct, finance, operate, or maintain the Project or interconnection facilities or to generate or sell the Project electric output.
- 1.58 "Person" means an individual, partnership, corporation, limited liability company, joint venture, association, trust, unincorporated organization, Governmental Authority, or other form of legal entity.
- 1.59 "Product" means, on and after the Effective Date, any and all Energy Output, Capacity Attributes, and Ancillary Services.
- 1.60 "Project" means the Biomass Asset and all related equipment, structures, electrical lines, and other facilities installed at the Site on Seller's or Operator's side of the point of interconnection under the Interconnection Agreement that is used for the production, control, delivery, or monitoring of electric energy described in Exhibit D-1.
- 1.61 "Project Maintenance" means Seller's or Operator's planned partial or complete reduction of the Project's generating capability for routine maintenance purposes.
- 1.62 "Proper Invoice" means a numbered and dated invoice with a detailed accounting of the amounts of any and all Energy Output delivered during the invoice period (if any), which states this TVA contract number, purchase order number, and contains the Contract Price for the Energy Output and a brief statement of payment terms, consistent with this Agreement, and other details and supporting documentation, as required by this Agreement.
- 1.63 "Qualified Bank" means a U.S. commercial bank or a U.S. branch of a foreign bank, with such bank having a credit rating on its senior unsecured debt of (a)(1) "A3" or higher from Moody's or (2) "A-" or higher from S&P, or (b) if rated by both Moody's and S&P, both (a)(1) and (a)(2).
- 1.64 "Settlement Amount" has the meaning set forth in Section 8.3.
- 1.65 "Site" means the land on which the Project is located, as more specifically described in Exhibit D-1.
- 1.66 "Biomass Asset" means the biomass generating facility to be located at the Site as further described in Exhibit D-1.

- 1.67 "S&P" means the Standard & Poor's Rating Group (a division of McGraw-Hill, Inc.) or its successor.
- 1.68 "Term" has the meaning set forth in Article II.
- 1.69 "Termination Payment" has the meaning set forth in Section 8.3.
- 1.70 [Reserved]
- 1.71 [Reserved]
- 1.72 [Reserved]
- 1.73 [Reserved]
- 1.74 "TVA Power Service Area" means the area served at retail by either TVA or distributors of TVA power in conformity with section 15d(a) of the TVA Act, as amended, 16 U.S.C. § 831n-4(a).
- 1.75 "Frontend PPA" has the meaning set forth in the recitals.

## ARTICLE II: TERM

This Agreement shall become effective as of the Effective Date and, unless otherwise terminated or extended in accordance with the provisions of this Agreement, shall remain in full force and effect until the earlier of: (a) five (5) years from the Effective Date; or (b) the termination or expiration of the Frontend PPA.

## ARTICLE III: THE PROJECT

### Section 3.1 Project Costs.

a) TVA will not be responsible under this Agreement for any costs or expenses (including overheads and administrative costs) or risks incurred in connection with the design, construction, installation, operation, or maintenance of any interconnection facilities up to the Delivery Point.

(b) Within thirty (30) days of the Effective Date, Seller shall provide a copy to TVA of the Frontend PPA, and in producing a copy of the Frontend PPA, Seller may redact pricing information from the copy that it provides to TVA.

### Section 3.2 Frontend PPA. Seller agrees that:

- (a) It has entered into, or will enter into within thirty (30) days of the Effective Date, the Frontend PPA with Operator, and
- (b) The Frontend PPA will have an initial term of not longer than thirty (30) years from the Effective Date and includes, or will include:
- (i) provisions that ensure Seller is able to fulfill its obligations under this Agreement, including the obligations to provide TVA with Product, Energy Output, Contract Output, Capacity Attributes, and Ancillary Services, metering, and the implementation of Curtailment instructions from TVA,
  - (iii) The provisions set forth in Exhibit C-1 to require the Operator to follow certain requirements under TVA's Flexibility Program Guidelines ("Guidelines") in effect as of the Effective Date (a copy of which is attached as Exhibit C-2), and a statement

providing that the applicable requirements of the Guidelines control in the event of a conflict between the Frontend PPA and the Guidelines, provisions that require the transfer of all Environmental Attributes to the Seller in accordance with the Guidelines, and

- (iv) The provisions set forth in Exhibit C-3 to this Agreement. Upon TVA's request, Seller agrees to undertake Commercially Reasonable efforts to enforce any of the Frontend PPA provisions required under this Section 3.2.
- (c) Seller's inclusion in the Frontend PPA of the provisions described in subsections (b)(iii) and (iv) immediately above, TVA's approval of the Initiation Notice Form for the Project, and Seller's compliance with the obligations set forth in subsection (c), immediately above, shall fully satisfy Seller's obligations under the Guidelines and the Power Supply Flexibility Agreement to incorporate terms into the Frontend PPA.

A failure of Seller to comply with its obligations under this Section 3.2 will constitute a failure to perform a material obligation under Section 8.1(c).

#### **ARTICLE IV: ENERGY OUTPUT, OTHER PROJECT ATTRIBUTES, AND PRICING**

Section 4.1 Energy Output. Commencing on the Effective Date and continuing through the end of the Term, Seller shall sell and deliver to TVA, and TVA shall purchase and receive from Seller, any and all right, title, and interest in and to the Energy Output at the Delivery Point. Energy Output shall be deemed made available to TVA for billing and payment purposes under Section 4.4 and Article X in the Month in which Energy Output is made available at the Delivery Point.

Section 4.2 Capacity Attributes. In accordance with and subject to the terms and conditions of this Agreement, commencing on the Effective Date and continuing through the end of the Term, Seller shall deliver to TVA, and TVA shall receive from Seller, any and all right, title, and interest in and to all Capacity Attributes available with respect to the Project.

Section 4.3 Ancillary Services. In accordance with and subject to the terms and conditions of this Agreement, commencing on the Effective Date and continuing through the end of the Term, Seller shall transfer to TVA, and TVA shall receive from Seller, any and all right, title, and interest in and to all Ancillary Services available with respect to the Project. Ancillary Services shall include the provision of primary frequency response with a maximum 5 percent droop and  $\pm 0.036$  Hz deadband. Seller's provision of Ancillary Services shall be at no additional cost to TVA.

#### Section 4.4 Pricing.

(a) In consideration for the Product, TVA shall pay Seller the applicable Contract Price for each hour that Seller (a) provides Energy Output from the Project, or (b) is economically curtailed by TVA as described in Section 7.2. The price payable shall be equal to \$49.15/MWh plus the Standard Service Total Monthly Fuel Cost, as set forth in the fuel cost adjustment Statement of Amounts, for the corresponding payment month (the "Contract Price").

(b) TVA shall adjust the Contract Price consistent with adjustments, increase or decrease, to Standard Service Wholesale rate changes and adjustments. TVA will make any such adjustment by delivering written notice to Seller referencing this subsection and setting forth the new Contract Price and the effective date for the Contract Price change.

(c) In the event Seller serves TVA notice of intent to terminate the Power Contract or causes the expiration without renewal or extension of the Power Contract, the Contract Price paid to Seller under this Agreement in such event shall be the Dispersed Power Production (DPP) rate paid by TVA under its

Dispersed Power Production program or a successor program; provided, however, that the following occurrences will not result in a change to the Contract Price under this Section 4.4(d): (i) if notice of intent to terminate the Power Contract is given by Seller due to TVA default, or (ii) if the Power Contract is terminated by Seller due to a TVA default thereunder that is not cured within any applicable cure period.

(d) Notwithstanding provision (a) of Article II or subsection (d), immediately above, in the event that Seller makes a permitted assignment in accordance with Section 10.2(b), below, this Agreement shall continue in full force and effect and the Valley Partner-assignee(s) shall continue to receive compensation for Energy Output in accordance with subsections (a) through (c) above.

## **ARTICLE V: METERING AND ATTESTATION**

Section 5.1 Metering Arrangements. Seller, or at TVA's discretion, Operator or an agent of Seller, shall enter into separate contractual arrangements with TVA, as the case may be, for the installation, operation, maintenance, and reading of the metering and related facilities ("Metering Equipment"). The Metering Equipment shall be used to determine the amount of energy delivered to and purchased by TVA at the Delivery Point under this Agreement.

Section 5.2 Meter Testing. These separate arrangements shall provide for TVA to make periodic tests and inspections of the Metering Equipment in order to maintain a high standard of accuracy. If tests show that the meter(s) are accurate within an acceptable threshold, fast or slow, as set forth under the separate arrangements, no adjustment shall be made to the payments submitted by TVA to Seller pursuant to Section 9.2. In case any tests show the meter(s) to exceed the acceptable threshold, fast or slow, adjustments shall be made to the payments submitted by TVA to Seller pursuant to Section 9.2 for any known or agreed upon period of inaccuracy; in the absence of any such knowledge or agreement, the adjustment shall be limited to one-half the period of time from the date of the last previous test of the meter(s) and the most recent test, but in no event shall the period covered by the correction exceed one hundred eighty (180) days.

Section 5.3 Attestations. Upon TVA's request, Seller shall provide or cause Operator to provide, at no cost to TVA, routine and non-routine attestations and other verifications of the delivery of any or all of the Energy Output and Other Project Attributes from the Project to demonstrate performance under this Agreement.

## **ARTICLE VI: MAINTENANCE AND OUTAGES**

Section 6.1 Scheduled Outages. Seller shall provide, or cause to be provided, to TVA a schedule for Project Maintenance no later than thirty (30) calendar days before the Effective Date for the period from such date through the end of the first Delivery Period. Seller shall submit to TVA a schedule for Project Maintenance no later than each subsequent December 1st, applicable to the following calendar year. To the extent practicable, Project Maintenance will be scheduled during the Months of October, November, March, and April, or during non-daylight hours.

Section 6.2 Forced Project Outages. As soon as practicable after commencement of a Forced Project Outage, Seller shall provide TVA with notice and expected duration of such Forced Project Outage. Each such notice shall set forth, to the extent of Seller's knowledge and judgment, a detailed explanation for the cause of the Forced Project Outage, identification of the equipment impacted, the expected duration of the Forced Project Outage, and Seller's proposed course of action to remedy such event and prevent similar future events.

Section 6.3 Project Description and Characteristics. Exhibit D-1 provides a detailed description of the Project. Exhibit D-1 provides additional information with respect to major equipment and components expected to make up the Project. Seller shall provide advance written notice to TVA at the earliest practicable time of any proposed changes to Exhibit D-1. Seller shall also provide advance written notice to TVA at the earliest practical time regarding any proposed changes to equipment that may alter generation capabilities other than capacity or items set forth in Exhibit D-1. Seller shall also periodically report to TVA any changes to Exhibit D-1.

#### **ARTICLE VII: DISCONNECTION OR CURTAILMENT**

Section 7.1 Disconnection of Project or Curtailment of Deliveries. In order to remain consistent with Good Utility Practice or compliant with Applicable Law, TVA may require Seller: (1) to effect a Curtailment of deliveries from the Project or (2) to temporarily disconnect the Project from the TVA transmission system, as necessary or appropriate to eliminate adverse impacts attributable to operation of the Project, including the following circumstances, whether such circumstances exist on the TVA transmission system, Seller's transmission system, or another system:

- (a) if a condition exists that presents an imminent physical threat to persons or property and disconnection or Curtailment appears necessary to protect such persons or property; or
- (b) to overcome transmission or distribution system reliability problems; or
- (c) if such disconnection or Curtailment is necessary to construct, install, maintain, repair, replace, remove, investigate, inspect, or test any affected part of the TVA transmission system or Seller's transmission system; or
- (d) to comply with applicable NERC standards, including those relating to TVA's role as a balancing authority; or
- (e) as permitted under any other express provisions of this Agreement that provide for any such disconnection or Curtailment.

Section 7.2 Economic Curtailment. Notwithstanding the foregoing, TVA shall have the right to curtail Project energy based on TVA power system cost in order to effectively manage the economics of the overall TVA power system. For any Month in which TVA has curtailed the Project for any reason other than as set forth in Section 1.17 or Section 7.1 (but excluding Section 7.1(e)), TVA shall pay Seller, in addition to amounts otherwise due, an amount equal to the Contract Price multiplied by the estimated amount of such curtailed energy. The Parties shall estimate the expected amount of such economically curtailed energy that would have been generated but for the curtailment, in a Commercially Reasonable manner, consistent with Good Utility Practice, for each hour during the economic curtailment period.

#### **ARTICLE VIII: DEFAULT; EARLY TERMINATION; REMEDIES**

Section 8.1 Events of Default. An "Event of Default" means, with respect to a Party or Seller (including an Affiliate of Seller), as specified (a "Defaulting Party"), the occurrence of any of the following:

- (a) the failure by a Party to make, when due, any payment required pursuant to this Agreement, including a failure to pay liquidated damages, if such failure is not remedied within twenty (20) Business Days after receipt of written notice from the other Party;
- (b) any representation or warranty made by such Party in Section 13.1 is false or misleading in any material respect as of the Effective Date, or with regard to the representations and warranties set forth in Section 13.1(a) through (d), at any time during the Term;

(c) the failure to perform any material covenant or obligation set forth in this Agreement (except to the extent addressed as a separate Event of Default under another subsection of this Section 8.1, and except for the failure of Seller or TVA to comply with an obligation under this Agreement for which a specific remedy has been agreed upon) if such failure is not remedied within thirty (30) calendar days after written notice from the other Party; provided, however, that if such failure is not reasonably capable of being remedied within the thirty (30) day cure period, such Party may have up to an additional fifteen (15) calendar days to remedy such failure, so long as such Party promptly commences and diligently pursues such remedy and provides to the other Party a written action plan therefor;

(d) the filing of an involuntary petition in bankruptcy or any involuntary proceeding under any other insolvency law against a Party as debtor and the failure to have the same dismissed within one hundred and twenty (120) calendar days from the date of filing;

(e) the filing by a Party of a voluntary petition in bankruptcy or for insolvency or reorganization or arrangement under the bankruptcy laws of the United States or under any insolvency act of any state, or a Party voluntarily taking advantage of any such law or act by answer or otherwise;

(f) such Party consolidates or amalgamates with, or merges with or into, or transfers all or substantially all of its assets to, another entity and, at the time of such consolidation, amalgamation, merger, or transfer, the resulting surviving or transferee entity fails to assume all the obligations of such Party under this Agreement to which it or its predecessor was a party by operation of law or pursuant to an agreement reasonably satisfactory to the other Party;

(g) the Biomass Asset at any time after the Effective Date fails to generate and deliver electric power and energy exclusively from biomass by means of generation set forth in Exhibit D-1;

(h) Seller's failure to deliver any Other Project Attributes associated with the Project; or

(i) Operator breaches or causes an event of default under the Interconnection Agreement, or any other written agreement between Operator and TVA that is necessary for TVA to receive Energy Output (each an "Operator Agreement") and such event of default is not cured by the time provided in said agreement.

Notwithstanding the provisions of subsection (i), in the event that Operator breaches or causes an event of default under a Operator Agreement (each, an "Operator Default"), such occurrence shall not become an Event of Default unless TVA serves a copy of any written notice of such Operator Default on Seller. Notwithstanding anything to the contrary in this Agreement or in the relevant Operator Agreement, Seller shall have the right to cure, or cause to be cured, the Operator Default at any time within thirty (30) days after Seller receives notice of such Operator Default from TVA, and if Seller determines that such Operator Default (other than a monetary Operator Default) cannot be cured within such thirty (30) day period, Seller shall have such further time to cure the Operator Default as is reasonably necessary so long as Seller promptly provides notice to TVA of its intent to cure and Seller proceeds with reasonable diligence to cure the Operator Default. Notwithstanding Seller's cure rights with regard to a Operator Default under this paragraph, TVA will continue to have the right to exercise remedies under the Operator Agreement other than termination of the Operator Agreement, including remedies related to safety, reliability, performance assurance, and suspension of performance.

## Section 8.2 Remedies for an Event of Default.

(a) Subject to Article XII, Seller shall have the right, but not the obligation, to do one or more of the following upon the occurrence of, and after providing written notice to TVA of, TVA's Event of Default:

(i) suspend performance of its obligations under this Agreement, including withholding any payments due to TVA under this Agreement; provided, however, in no event shall

any such suspension continue for longer than ten (10) Business Days unless an Early Termination Date shall have been declared and notice thereof given pursuant to Section 8.3; or

(ii) declare an Early Termination Date and receive a Termination Payment from TVA.

(b) Subject to Article XII, TVA shall have the right, but not the obligation, to do one or more of the following upon the occurrence of, and after providing written notice to Seller of, Seller's Event of Default:

(i) suspend performance of its obligations under this Agreement, including withholding any payments due to Seller under this Agreement; provided, however, in no event shall any such suspension continue for longer than ten (10) Business Days unless an Early Termination Date shall have been declared and notice thereof given pursuant to Section 8.3;

(ii) make a written request and draw upon the Performance Assurance that Seller provided to satisfy any and all payments due and amounts otherwise owing (including any liquidated damages) under this Agreement; or

(iii) declare an Early Termination Date and receive a Termination Payment from Seller.

The remedies set forth in this Section 8.2 shall constitute the Non-Defaulting Party's sole and exclusive remedies for an Event of Default.

**Section 8.3 Declaration of an Early Termination Date and Calculation of Settlement Amounts.** If an Event of Default with respect to a Defaulting Party occurs and is continuing, the other Party ("Non-Defaulting Party") may designate a day, no earlier than the day such notice is effective and no later than twenty (20) calendar days after such notice is effective, as an early termination date ("Early Termination Date") to accelerate all amounts owing between the Parties and to liquidate and terminate this Agreement; provided that the Early Termination Date shall be no earlier than the date the Non-Defaulting Party notifies the Defaulting Party of the Early Termination Date and no later than twenty (20) calendar days after such notification of the Early Termination Date. The Non-Defaulting Party shall calculate, in a Commercially Reasonable manner, a Settlement Amount for this Agreement as of the Early Termination Date, which Settlement Amount will then be considered due and owing. In making the calculation described in the foregoing sentence, the "Settlement Amount" means the Non-Defaulting Party's Losses or Gains, and Costs, expressed in U.S. Dollars, which such Party incurs as a result of the liquidation and termination of this Agreement pursuant to this Section. The Non-Defaulting Party shall aggregate the Settlement Amount with all other amounts due to the Non-Defaulting Party under this Agreement so that all such amounts constitute a single liquidated amount (the "Termination Payment"). Notwithstanding the foregoing, Seller will not owe TVA a Termination Payment if the basis for TVA's declaration of an Early Termination Date is a breach under Section 8.1(i).

**Section 8.4 Notice of Termination Payment Amount.** As soon as practicable after a declaration of an Early Termination Date, the Non-Defaulting Party shall give notice to the Defaulting Party of the amount of the Termination Payment (if any). The notice shall include a request for payment and a written statement explaining in reasonable detail the calculation of such amount and the sources for such calculation. The Defaulting Party shall pay the Termination Payment to the Non-Defaulting Party within five (5) Business Days after receiving a request for the same.

**Section 8.5 Disputes with Respect to Termination Payment.** If the Defaulting Party disputes the Non-Defaulting Party's calculation of the Termination Payment, in whole or in part, the Defaulting Party shall, within ten (10) Business Days after receipt of Non-Defaulting Party's calculation of the Termination Payment, provide to the Non-Defaulting Party a detailed written explanation of the basis for and extent of such dispute; provided, however, that if Seller is the Defaulting Party, Seller shall first



ensure that TVA holds Performance Assurance in the form of Cash (whether through draws on any Letter of Credit held as Performance Assurance or otherwise) in an amount equal to the disputed portion of the Termination Payment.

#### **ARTICLE IX: BILLING AND PAYMENT**

Section 9.1 Billing. Based on recorded meter data provided by the Metering Equipment installed per Section 5.1 ("Meter Readings"), and after receipt of a Proper Invoice TVA shall pay the Contract Price for the Energy Output from the Project (as applicable) to Seller each Month of the Term.

Section 9.2 Payment. Seller must provide a Proper Invoice to TVA based on said Meter Readings, within ten (10) Business Days following the Month of actual energy delivery. Unless Seller requests early payment as specified below, upon receipt of a Proper Invoice TVA shall promptly pay Seller within thirty-five (35) calendar days or if the thirty-fifth (35th) calendar day is not a Business Day, then on the next Business Day. Each payment to Seller shall be made electronically through the Automated Clearing House (ACH) network to Seller's account as designated by Seller.

Section 9.3 Early Payment. Seller may request early payment by stating such request both in a Proper Invoice and in an accompanying transmittal message (e.g., email). Upon receipt of such request for early payment, TVA shall apply a three (3) percent early payment discount to the total monthly invoice payment and shall promptly pay Seller within ten (10) calendar days or if the tenth (10th) calendar day is not a Business Day, then by the first Business Day following such calendar day.

Section 9.4 Invoice Submittal. Seller shall submit all invoices, including supporting documentation, electronically to TVA at [SettlementsFA@tva.gov](mailto:SettlementsFA@tva.gov), [Solarprojects@tva.gov](mailto:Solarprojects@tva.gov), [Flexibility@tva.gov](mailto:Flexibility@tva.gov), and [AssetManagement@tva.gov](mailto:AssetManagement@tva.gov).

Section 9.5 Netting. Amounts owed by each Party to the other Party during a monthly billing period under this Article IX shall be offset against each other so that only one Party shall pay a net amount to the other Party.

Section 9.6 Offset. If Seller is in breach of any requirement of this Agreement or any other agreement with TVA, TVA may withhold payments that may be due to Seller and may offset any costs incurred by TVA as a result of the breach, other damages, or monies owed to TVA against funds due Seller under this or any agreement that Seller has with TVA.

#### **ARTICLE X: PERFORMANCE ASSURANCE, ASSIGNMENT, AND PROJECT FINANCE**

Section 10.1 Performance Assurance. Seller shall provide and maintain the Performance Assurance in compliance with Exhibit A, and consistent with the Long-Term Partner Benefit provision in 15.23, for the duration of the Term of this Agreement.

Section 10.2 Assignment.

(a) Except as otherwise expressly set forth in this Section, neither Party will assign this Agreement nor any of its rights or obligations hereunder (including any collateral assignment of its rights or interest in connection with any financing related to the construction, operation, or maintenance of the Project) without the prior, written consent of the other Party, which consent shall not be unreasonably withheld. Without such consent from TVA, Seller may assign, transfer, or pledge its interest in the revenues and payments to be made under this Agreement. Further, neither Party may, without the other Party's written consent, which shall not be unreasonably withheld, enter into any transaction or series of transactions in which a third party obtains more than a 50% controlling interest in the Party ("Change of Control"). In the event Seller's rights, interests, or obligations under this Agreement are assigned or

assumed as a matter of law to an entity with which Seller is merged or consolidated (“Successor Seller”), any such assignment or assumption shall be contingent upon Seller and Successor Seller furnishing TVA with adequate assurances that the Successor Seller is financially capable of performing Seller’s obligations under this Agreement. No assignment, transfer, or pledge of Seller’s or a Successor Seller’s interests in the Agreement shall release the assignor, pledger, or transferor from any of its obligations under this Agreement to accrue prior to such assignment, transfer, or pledge. Except as stated above, either Party’s purported assignment of this Agreement, in whole or in part, or a Change in Control, without the prior, written approval of the other Party is null and void.

(b) Notwithstanding the provisions of subsection (a), Seller may assign its interest in this Agreement to one or more assignees; provided that (i) each assignee is a “Valley Partner” that is eligible to purchase and sell such Energy Output in accordance with its own Power Supply Enhanced Flexibility Agreement with TVA, (ii) the assignee or group of assignees agree to assume all of Seller’s obligations under this Agreement pursuant to an assignment and assumption agreement that is acceptable to TVA, in its reasonable discretion, (iii) Seller assigns to assignee(s), and assignee(s) assume, all of Seller’s rights and obligations under the Frontend PPA and such assignment and assumption is allowed under the Frontend PPA or the Operator consents to such assignment and assumption, and (iv) TVA consents to the assignment, which consent may not be unreasonably withheld. Seller shall continue to be responsible for its obligations under this Agreement unless and until TVA consents to the assignment and releases Seller from its obligations under this Agreement.

(c) TVA shall, within fifteen (15) Business Days of written request from Seller, execute and deliver to seller an estoppel certificate regarding this Agreement, such estoppel certificate to confirm (to the extent accurate) that this Agreement remains in force and effect (and identifying any amendments to the Agreement, if any), that to TVA’s knowledge there are no defaults existing or alleged to exist under the Agreement, that to TVA’s knowledge all obligations under the Agreement have been performed by the parties and are current (including payment obligations), and otherwise such estoppel certificate to be in a form and content as agreed upon between the parties.

## **ARTICLE XI: LIMITATIONS**

### **Section 11.1 Limitations of Liability.**

UNLESS EXPRESSLY HEREIN PROVIDED, NEITHER PARTY WILL BE LIABLE TO THE OTHER PARTY FOR CONSEQUENTIAL, INCIDENTAL, PUNITIVE, EXEMPLARY, OR INDIRECT DAMAGES, LOST PROFITS, OR OTHER BUSINESS INTERRUPTION DAMAGES, IN TORT OR CONTRACT, UNDER ANY PROVISION OF THIS AGREEMENT.

THE LIMITATIONS OF LIABILITY STATED IN THIS SECTION ARE IMPOSED WITHOUT REGARD TO THE CAUSE OR CAUSES RELATED THERETO, INCLUDING THE NEGLIGENCE OF EITHER PARTY, WHETHER SUCH NEGLIGENCE BE SOLE, JOINT, OR CONCURRENT, OR ACTIVE OR PASSIVE.

### **Section 11.2 Liquidated Damages.**

WHERE THIS AGREEMENT SPECIFIES THAT SELLER WILL BE LIABLE, DUE TO SELLER FAILURE(S) OR ACTION(S), TO PAY TVA MONETARY DAMAGES IN CONNECTION WITH SUCH FAILURE(S) OR ACTION(S), THE PARTIES AGREE THAT THESE ARE LIQUIDATED DAMAGES, AND AS SUCH, THESE DAMAGES ARE: (A) REASONABLE APPROXIMATIONS OF AND STATE ADEQUATE REMEDIES FOR THE SUBJECT HARM OR LOSSES, (B) IN LIEU OF ACTUAL DAMAGES, WHICH WOULD BE DIFFICULT OR IMPOSSIBLE TO QUANTIFY, (C) NEITHER PENAL NOR PUNITIVE, AND (D) NOT SUBJECT TO THE LIMITATIONS OF LIABILITY SET FORTH IN SECTION 11.1.

## ARTICLE XII: GOVERNMENTAL CHARGES

Section 12.1 Cooperation. Each Party shall use Commercially Reasonable efforts to minimize all taxes, so long as neither Party is materially adversely affected by such efforts.

Section 12.2 Governmental Charges. Seller shall pay or cause to be paid all taxes imposed by any Governmental Authority ("Governmental Charges") on or with respect to the Product arising prior to the Delivery Point. TVA shall pay or cause to be paid all Governmental Charges on or with respect to the Product at and from the Delivery Point (other than ad valorem, franchise, or income taxes that are related to the sale of the Product and are, therefore, the responsibility of Seller). In the event Seller is required by Applicable Law to remit or pay Governmental Charges that are TVA's responsibility hereunder, TVA shall promptly reimburse Seller for such Governmental Charges. If TVA is required by Applicable Law to remit or pay Governmental Charges that are Seller's responsibility hereunder, TVA may offset the amount of any such Governmental Charges against sums due to Seller under this Agreement. Nothing shall obligate or cause a Party to pay or be liable to pay any Governmental Charges for which it is exempt under Applicable Law. Each Party shall cooperate with the other Party in order to qualify for or take advantage of any available reduction in or exemption from such Governmental Charges and to otherwise minimize the amount of such Governmental Charges that must be paid under Applicable Law.

## ARTICLE XIII: REPRESENTATIONS AND WARRANTIES

Section 13.1 Representations and Warranties. As of the Effective Date, each Party represents and warrants to the other Party that:

- (a) it is duly organized, validly existing, and in good standing under the laws of the jurisdiction of its formation;
- (b) it has all regulatory authorizations necessary for it to legally perform its obligations under this Agreement, except those authorizations which Seller reasonably expects to receive in the ordinary course, e.g., those required to be obtained from or with the cooperation of TVA;
- (c) the execution, delivery, and performance of this Agreement are within its powers, have been duly authorized by all necessary action, and are not inconsistent with any of the terms and conditions in its governing documents, any contracts to which it is a party, or any Applicable Law;
- (d) this Agreement and each other document executed and delivered in accordance with this Agreement constitutes its legally valid and binding obligation enforceable against it in accordance with its terms, subject to any equitable defenses;
- (e) it is not Bankrupt and there are no proceedings pending or being contemplated by it or, to its knowledge, threatened against it that would result in it being or becoming Bankrupt;
- (f) there is not pending or, to its knowledge, threatened against it or any of its Affiliates, any legal proceedings that could materially adversely affect its ability to perform its obligations under this Agreement;
- (g) nothing which would constitute an Event of Default with respect to it has occurred and is continuing and no such event or circumstance would occur as a result of its entering into or performing its obligations under this Agreement;
- (h) it is acting for its own account, has made its own independent decision to enter into this Agreement and as to whether this Agreement is appropriate or proper for it based upon its own judgment, is not relying upon the advice or recommendations of the other Party in so doing, and is capable of

assessing the merits of and understanding, and understands and accepts, the terms, conditions, and risks of this Agreement;

(i) the parties intend for this Agreement to be a “forward contract” as defined in 11 U.S.C. § 101(25);

(j) it has entered into this Agreement in connection with the conduct of its business and it has the due capacity or ability to make or take delivery of all Products referred to in this Agreement;

(k) with respect to the purchase or sale of a Product, it is a producer, processor, commercial user, or merchant handling the Product, and it is entering into this Agreement for purposes related to its business as such; and

(l) it is an “eligible contract participant” within the meaning of the United States Commodity Exchange Act.

EXCEPT AS SET FORTH EXPLICITLY IN THIS AGREEMENT, THERE IS NO WARRANTY OF MERCHANTABILITY OR FITNESS FOR A PARTICULAR PURPOSE, AND ANY AND ALL IMPLIED WARRANTIES ARE DISCLAIMED.

#### **ARTICLE XIV: FORCE MAJEURE**

Section 14.1 Force Majeure Occurrence and Notice. To the extent that any Party is prevented by a Force Majeure Event from performing, in whole or in part, its obligations under this Agreement (other than the obligation to pay money) or from complying with, in whole or in part, requirements under this Agreement, such Party (the “Claiming Party”) shall give notice and details of the Force Majeure Event to the other Party as soon as practicable. In addition, any completion milestones or deadlines or time periods by which performance is due will be extended for a period of time equal to the time period during which such Force Majeure Event actually prevents the Claiming Party’s performance. The Claiming Party shall use Commercially Reasonable efforts to remedy the Force Majeure Event and mitigate any adverse effects on the performance of its obligations under this Agreement. The Claiming Party shall promptly notify the other Party when it is able to resume performance of its obligations and compliance with such conditions under this Agreement, if it is able to do so. Until the other Party is so notified, it shall not be required to perform or resume performance of its obligations to the Claiming Party corresponding to the obligations of the Claiming Party excused by a Force Majeure Event. No Party will be relieved or excused by operation of this Article XIV of any liability for breach of any obligations that were to be performed or that accrued before the Force Majeure Event. If the Force Majeure Event does not entirely prevent Seller from providing Energy Output and Other Project Attributes, then Seller shall provide Energy Output and Other Project Attributes not so prevented. If deliveries of Energy Output or Other Project Attributes are prevented in whole or in part by a Force Majeure Event, the deliveries in question shall not be made up and the Term shall not be extended to permit any makeup or offset of the lost deliveries.

#### **ARTICLE XV: MISCELLANEOUS**

Section 15.1 Title. Delivery of any and all Energy Output and Other Project Attributes being purchased by TVA shall be deemed completed at the Delivery Point, and title to such Energy Output shall pass to TVA upon delivery thereto.

Section 15.2 Waiver. The non-exercise of, or delay in exercising, any power or right of a Party does not operate as a waiver of that power or right, nor does any single exercise of a power or right preclude any other or further exercise of it or the exercise of any other power or right. A power or right may only be waived in writing, signed by the Party to be bound by the waiver.

Section 15.3 Choice of Law. This Agreement shall be governed, construed and interpreted in accordance with the Federal laws of the United States of America.

Section 15.4 Exhibits Made Part of this Agreement. The Exhibits identified in, and attached to, this Agreement are made a part of this Agreement.

Section 15.5 Approvals. Each Party hereto shall use Commercially Reasonable efforts and shall cooperate with the other to obtain any Permit. TVA, however, shall not be obligated to obtain any Permit or have financial responsibility for obtaining any Permit.

Section 15.6 Severability. In the event that any of the terms, covenants, or conditions of this Agreement, including its Exhibits, or the application of any such term, covenant, or condition shall be held invalid by any court or administrative body having jurisdiction, it is the intention of the Parties that in lieu of each such term, covenant, or condition that is held invalid, the Parties shall negotiate a valid term, covenant, or condition as similar in effect as possible to such invalid term, covenant, or condition. The Agreement shall not otherwise be affected thereby and shall remain in full force and effect.

Section 15.7 Integration. The terms and provisions contained in this Agreement between the Parties constitute the entire agreement between the Parties, and supersede all previous communications and representations, either oral or written, between the Parties with respect to the subject matter of this Agreement.

Section 15.8 Notices and Payments.

(a) Notices and Invoices. Except as otherwise expressly provided under this Agreement, any notice or invoice provided for in this Agreement must be in writing and shall be effective on the day on which it is actually received (provided that such day is a Business Day, otherwise it shall be deemed to be received on the first Business Day immediately following such day), in person, by U.S. Mail, by other nationally recognized delivery service, or by e-mail or facsimile transmission at the addresses provided set forth below:

If to TVA:

Tennessee Valley Authority  
1101 Market Street, MR 2C  
Chattanooga, TN 37402  
Attention: Director, Origination & Utility Scale Solar

Email: [AssetManagement@tva.gov](mailto:AssetManagement@tva.gov) and [Solarprojects@tva.gov](mailto:Solarprojects@tva.gov)

If to Seller:

Knoxville Utilities Board  
445 South Gay Street  
Knoxville, TN 37902  
Attention: Gabe Bolas, President and Chief Executive Officer  
Email: [execdept@kub.org](mailto:execdept@kub.org)

(b) Payments. All payments required to be made to TVA under this Agreement shall be made by Automated Clearing House (ACH) to the following account (or to other account as may subsequently be designated by TVA), with the amounts deemed received as of the date the electronic fund transfer to the recipient's account is deemed effective:

Depository Institution Name: Credit Gateway-ACH Receiver  
Address: 60 Livingston Avenue

St. Paul, Minnesota 55207  
ABA Routing Number: 051036706  
Receiving Company Name: Tennessee Valley Authority  
DFI Account Number: 349000  
Standard Entry Class: CCD+  
Transaction Code: 22  
Employer Identification No (EIN): 62-0474417

All payments required to be made to Seller under this Agreement shall be made by wire to:

Depository Institution Name: First Horizon Bank  
Address: Memphis, TN  
Swift Code or ABA: 084000026  
Account Number: 179318042  
Receiving Company Name: KNOXVILLE UTILITIES BOARD  
Account Number: 179318042  
Employer Identification No (EIN): 62-6000324

Section 15.9 Audit.

(a) The Parties shall maintain accurate records and books of account. Said books and records shall present fairly all costs and expenses utilized in computing any charges or payments to the other Party under this Agreement.

(b) Each Party shall have the right at its own expense, upon two Business Days' advance notice and during normal business hours, to have its own personnel or its independent auditors inspect the books and records of the other Party hereto pertaining solely to the performance of this Agreement at the offices of the other Party, to the extent necessary to verify the amounts of energy delivered, the amounts owed to Seller by TVA, and any amount owed to TVA by Seller. The Party conducting the inspection shall use its best efforts to minimize any disruptions of the other Party's operations that might result from any such inspection. Nothing in this Section 15.9(b) shall diminish the rights of TVA's Office of the Inspector General to conduct any audit or inspection related to the Agreement.

(c) Upon at least ten (10) Business Days' prior written notice from TVA, and no more than once per Delivery Period, Seller shall make the Project, including records relating to its operations, maintenance, and warranty repairs, available to TVA for inspection during normal business hours.

Section 15.10 Dispute Resolution. Unless otherwise provided in this Agreement, the Parties agree to use their best efforts to resolve disputes related to this Agreement informally at the lowest possible levels of decision making. Disputes not resolved at the working level will be referred to higher levels of management of both Seller and TVA for consideration, as necessary, and resolution, if possible. Any legal or equitable action related to this Agreement shall be brought in the United States District Court for the Eastern District of Tennessee and THE PARTIES HEREBY WAIVE: (a) ANY OBJECTION TO THAT COURT'S JURISDICTION OVER THEM, OR THAT VENUE IS PROPER IN SUCH COURT, and (b) ANY RIGHT TO A JURY TRIAL. This Section 15.10 is not a Disputes clause within the meaning of the Contract Disputes Act of 1978, 41 U.S.C. §§ 601-613, and this Agreement is not subject to the provisions of such Act.

Section 15.11 Indemnity and Insurance.

(a) To the extent permitted under applicable law, Seller shall indemnify, defend, save, and hold harmless TVA and its directors, officers, employees, contractors, and agents from any and all claims for injury to persons or damage to property or the environment, including any adverse wildlife or environmental impacts, to the extent caused by: (i) Seller's negligent, reckless, or intentional acts or

omissions in conducting activities within the scope of this Agreement, or (ii) Seller's failure to comply with Applicable Law or the specific environmental requirements concerning the Project that are set forth in the Notice of Environmental Review Completion. Seller is solely responsible for the risk of loss of, or damage to, the Project, Site, or adjacent properties, except to the extent that the loss or damage results from the reckless or intentional acts or omissions of TVA and its directors, officers, employees, contractors, or agent.

(b) Seller shall maintain or cause to be maintained the insurance required by Exhibit B. Failure of Seller to do so shall be deemed a failure to perform a material covenant or obligation set forth in Section 8.1(c).

Section 15.12 Interpretation. Unless otherwise expressly stated, references in this Agreement to "Sections" are to Sections of this Agreement, references to "Articles" are to Articles of this Agreement, and references to "Exhibits" are to the Exhibits attached to this Agreement. All references to Sections in the Exhibits to this Agreement are to the Sections in the Exhibits in which they appear unless otherwise noted. All titles, headings, and similar items are provided for the purpose of reference and convenience and are not intended to affect the meaning of the contents or scope of this Agreement. Words defined in the singular have the corresponding meaning in the plural and vice versa. Use of "including" means including without limitation. References to one gender include all others. Any capitalized terms used in the Exhibits to this Agreement that are not specifically defined in such Exhibits shall have the meanings ascribed to them in this Agreement. Such Exhibits shall constitute a material part of this Agreement, and the provisions of such Exhibits shall be interpreted and enforced as if such provisions were directly set forth in this Agreement.

Section 15.13 No Partnership or Agency. Nothing in this Agreement shall be treated as creating a partnership or joint venture between the Parties under Applicable Law and, except as specifically provided in this Agreement, neither Party may act or have any authority to act as agent of or in any way bind or commit the other Party to any obligation.

Section 15.14 Costs and Expenses. Each Party shall bear and is responsible for its own costs (including attorney fees) in connection with the negotiation, preparation, execution, completion, implementation, and ongoing administration of this Agreement.

Section 15.15 Rights Cumulative. Except as specifically provided in this Agreement, the rights and remedies provided in this Agreement are cumulative with and do not exclude any rights or remedies provided by law.

Section 15.16 Amendment. This Agreement may be amended, changed, modified, altered, extended, or terminated, provided that such amendment, change, modification, alteration, extension, or termination shall be in writing and signed by both Parties.

Section 15.17 Survival of Obligations. Except as specifically provided in this Agreement, cancellation, expiration, or early termination of this Agreement shall not relieve the Parties of obligations that by their nature should survive such cancellation, expiration, or termination, including warranties, remedies, and promises of indemnity.

Section 15.18 Counterparts. This Agreement may be executed in two or more counterparts, each of which is signed by one of the Parties but all of which together shall constitute but one and the same agreement.

Section 15.19 Confidentiality.

(a) A Party may not disclose the terms of this Agreement or any confidential information provided hereunder that is conspicuously marked as confidential (together, "Confidential Information") to a third party except as follows (i) to the Party's parents, Affiliates, potential or existing investors, consultants, potential or existing lenders, counsel, counsel for potential or existing investors or lenders, or

accountants, or specific Seller customers receiving the benefit of Environmental Attributes associated with the Project, or prospective assignees permitted pursuant to Section 10.2 to the extent required for the consideration of an assignment, that have agreed in writing to keep the Confidential Information confidential on terms no less restrictive than those set forth in this Section, (ii) to comply with Applicable Law, or (iii) with the other Party's prior written approval.

(b) A Party shall promptly notify the other Party if it is required by Applicable Law to disclose Confidential Information so that the Party that owns or controls the Confidential Information may take action to prevent or limit the scope of such required disclosure.

(c) The Parties acknowledge and agree that disclosure or unauthorized use of information described in this Section 15.19 could damage the other Party and that said other Party, therefore, has an interest in protecting that information by all legal means, and further that breach of the promises set forth above could cause irreparable damage to the Party possessing proprietary rights in Confidential Information wrongfully disclosed, and still further that in the event of such breach, said Party shall have the right to an injunction, specific performance, or other equitable relief to prevent the violation of the promises mentioned above. Under 18 U.S.C. Section 1905, officers and employees of TVA may be subject to criminal liability in the event Confidential Information is disclosed unless such disclosure is authorized by law. Accordingly, Seller agrees that, in addition to the equitable relief identified above, Seller shall only be entitled to recover from TVA, its officers, agents, and employees any and all gains wrongfully acquired, directly or indirectly, from unauthorized disclosure of any Confidential Information.

Section 15.20 Project Communications. Seller will, when communicating publicly about the Project and associated RECs, identify TVA (by name or through the use of the TVA logo) in promotional efforts and materials associated with the Project. Use of the TVA logo must follow TVA's logo use guidelines. If Seller intends to include language in addition to TVA's name and/or logo, Seller must provide such language to TVA in advance for approval. Seller will notify TVA of public events in advance to enable reasonable efforts to participate. For the avoidance of doubt, this Section 15.20 does not prohibit Seller or Operator from making any public statements about the Project as required in the ordinary course of development, construction, operations and maintenance activities, such as, by way of example, public hearings to obtain zoning variances or development permits.

Section 15.21 Project Collaboration. The Parties will endeavor to find mutually agreeable opportunities for education and research that benefit the Parties, and/or specific customers served by distributors of TVA power receiving the benefit of Environmental Attributes associated with the Project.

Section 15.22 Service Contract. Each Party intends this Agreement to be a "service contract" within the meaning of Section 7701(e)(3) of the Internal Revenue Code of 1986.

Section 15.23 Long Term Partnership Benefit. As long as the notice period to terminate the Power Contract remains at twenty (20) year and Seller has not provided notice to terminate the Power Contract, Seller will not be required to provide any Performance Assurance to TVA, including but not limited to Article X and Exhibit A.

Section 15.24. Replacement PPA. In the event that TVA offers or otherwise makes available an updated flexibility option power purchase agreement for TVA-interconnected projects to other distributors of TVA power that have executed a long-term agreement with TVA under substantially the same terms as the current LTA, TVA will provide Seller at least ninety (90) days to evaluate the updated flexibility option power purchase agreements and, if Seller desires to adopt that agreement in place of this Agreement, TVA and Seller will engage in good faith discussions regarding the replacement of this Agreement with such substitute power purchase agreement and will endeavor to enter into such replacement power purchase agreement within a reasonable time after Seller notifies TVA that it desires to replace this Agreement.



Section 15.25. TVA Waiver. Solely for the purposes of this Agreement, TVA waives Seller's obligations regarding Continuous Reactive Power Support under the Participation Requirements section of the Guidelines.

[Signatures on following page]

IN WITNESS WHEREOF, the Parties have caused this Agreement to be executed as of the Effective Date.

KNOXVILLE UTILITIES BOARD  
(Acting for and on behalf of the City of Knoxville)

By: \_\_\_\_\_

Name: \_\_\_\_\_

Title: \_\_\_\_\_

TENNESSEE VALLEY AUTHORITY

By: \_\_\_\_\_

Name: \_\_\_\_\_

Title: \_\_\_\_\_

## EXHIBITS

Exhibit A	Credit Annex
Exhibit B	Insurance
Exhibit C-1	Provisions Relating to the Guidelines
Exhibit C-2	TVA's Flexibility Program Guidelines
Exhibit C-3	Legally Required Clauses
Exhibit D-1	Project Description

**EXHIBIT A**  
**CREDIT ANNEX**

Section 1      Amount of Performance Assurance and Notice of Material Credit Event

(a)Performance Assurance. Seller shall provide and maintain throughout the Term of this Agreement or cause to be provided Performance Assurance as follows based on the Contract Output of the Project on the Effective Date of this Agreement:

Milestone	\$/kW
Effective Date	\$170

Performance Assurance for the Effective Date Milestone must be provided to TVA prior to TVA's signature of this Agreement. TVA will not be obligated to return Performance Assurance as of the Effective Date or tenth anniversary of the Effective Date unless Seller has first provided TVA with replacement Performance Assurance meeting the requirements of this Agreement.

For the purpose of determining the amount of the required Performance Assurance, the Contract Output of the Project will be rounded up to the nearest whole kW.

(b)Notice of Material Credit Event. Seller shall notify TVA in writing of the occurrence of any event that, with notice or the passage of time or both, would constitute a Material Credit Event with respect to Seller, which notice shall be given by Seller within five (5) Business Days of the occurrence of such event. If at any time there shall occur a Material Credit Event with respect to Seller, and such Material Credit Event is not cured or replacement Performance Assurance is not provided within ten (10) calendar days' notice of such event, then an Event of Default shall be deemed to have occurred pursuant to Section 9.1(c) of the Agreement to which this Exhibit A is attached.

Section 2      Letter of Credit as Performance Assurance. If Performance Assurance consists of a Letter of Credit, such Letter of Credit shall:

(a) be issued by a Qualified Bank;

(b) permit TVA to draw up to the then current "Available Amount" as defined in the Letter of Credit for the purpose of paying any and all amounts owing to TVA under the Agreement to which this Exhibit A is attached following the occurrence and during the continuation of an Event of Default; and

(c) permit TVA to draw the entire "Available Amount" thereunder to hold as Cash collateral for any and all amounts owing to TVA under the Agreement to which this Exhibit A is attached if (i) the Letter of Credit will expire in fewer than forty-five (45) calendar days and (ii) the Seller has not provided TVA with alternative Performance Assurance.

Section 3      Substitution, Return, and Handling of Performance Assurance.

(a) Election to Change Form of Performance Assurance. Seller shall have the right to, at any time and from time to time, request replacement of any or all of the Performance Assurance provided by it (the "*Outstanding Performance Assurance*") with one or more alternative forms of

Performance Assurance, whereupon TVA shall cooperate with the Seller in obtaining the concurrent release, termination, or return (as many as may be applicable) of the Outstanding Performance Assurance in favor of or held by

(b) Return of Original Performance Assurance Documents. Without limitation to the generality of the foregoing, TVA shall return to the Seller all original Letter of Credit documents, and all amendment, extension, and other related documents, within sixty (60) days of the termination, cancellation, or replacement thereof.

Section 4      Financial Statements

(a) TVA's Financial Statements. If requested by Seller, TVA shall deliver (i) within 120 days following the end of each fiscal year, a copy of TVA's annual report containing audited consolidated financial statements for such fiscal year and (ii) within 60 days after the end of each of its first three fiscal quarters of each fiscal year, a copy of TVA's quarterly report containing unaudited consolidated financial statements for such fiscal quarter. In all cases the statements shall be for the most recent accounting period and prepared in accordance with generally accepted accounting principles; provided, however, that should any such statements not be available on a timely basis due to a delay in preparation or certification, such delay shall not be an Event of Default so long as TVA diligently pursues the preparation, certification, and delivery of the statements.

(b) Seller's Financial Statements. If requested by TVA, Seller shall deliver (i) within 120 days following the end of each fiscal year, a copy of the annual report containing audited consolidated financial statements for such fiscal year for Seller, or Seller's Affiliate, and (ii) within 60 days after the end of each of its first three fiscal quarters of each fiscal year, a copy of quarterly report containing unaudited consolidated financial statements for such fiscal quarter for Seller, or Seller's Affiliate. In all cases the statements shall be for the most recent accounting period and shall be prepared in accordance with generally accepted accounting principles; provided, however, that should any such statements not be available on a timely basis due to a delay in preparation or certification, such delay shall not be an Event of Default so long as the relevant entity diligently pursues the preparation, certification, and delivery of the statements.

**FORM LETTER OF CREDIT**

[LETTERHEAD]

[DATE]

Irrevocable Standby Letter of Credit No.

**Beneficiary:**

**Applicant:**

Tennessee Valley Authority  
400 West Summit Hill Drive, WT 4C  
Knoxville, TN 37902-1401

Attn: Name  
Director, Corporate Credit & Insurance

Dear Madam or Sir:

We hereby establish for the account of \_\_\_\_\_ (Seller) \_\_\_\_\_ (“Seller’s name” or “Applicant”), our irrevocable standby letter of credit in your favor for an amount of USD \_\_\_\_\_ (\_\_\_\_\_ Dollars United States currency) (the “LC Amount”). Applicant has advised us that this letter of credit is issued in connection with the \_\_\_\_\_ Agreement dated as of \_\_\_\_\_, 20\_\_, between Applicant and Beneficiary (as amended and as may be further amended, supplemented, or otherwise modified, the “\_\_\_\_\_ Agreement”). This letter of credit shall; (i) become effective immediately for the term of one (1) year and shall expire on \_\_\_\_\_ (the “Expiration Date”), and (ii) is subject to the following:

1. Funds under this letter of credit shall be made available to Beneficiary against its draft drawn on us in the form of Annex 1 hereto, accompanied by (a) a certificate in the form of Annex 2 hereto, appropriately completed and signed by an authorized representative of Beneficiary, dated the date of presentation and (b) the original of the letter of credit (the “Accompanying Documents”) and presented at our office located at \_\_\_\_\_, attention \_\_\_\_\_ (or at any other office that may be designated by us by written notice delivered to you). A presentation under this letter of credit may be made only on a day, and during hours, in which such office is open for business (a “Business Day”). If we receive your draft and the Accompanying Documents at such office on any Business Day, all in strict conformity with the terms and conditions of this letter of credit, we will honor the same by making payment in accordance with your payment instructions on the third succeeding Business Day after presentation. Within five Business Days after payment of any draw of the letter of credit, we shall provide you with a new letter of credit in the LC Amount.

2. This letter of credit shall terminate upon the earliest to occur of (i) our receipt of a notice in the form of Annex 3 hereto signed by an authorized representative of Beneficiary, accompanied by this letter of credit for cancellation, (ii) our close of business at our aforesaid office on the Expiration Date, or if the Expiration Date is not a Business Day, then on the following Business Day. This letter of credit shall be surrendered to us by you upon the earlier of presentation or expiration.

3. It is a condition of the letter of credit that it shall be deemed to be automatically extended without amendment for periods of one (1) year from the present or any future expiration date, unless at least forty-five (45) days prior to any such expiration date we send you notice by registered mail, return receipt requested or courier service or hand delivery at the above address that we hereby elect not to consider this letter of credit extended for any such additional period.

4. This letter of credit is issued and subject to the International Standby Practices 1998 (ISP98).

5. This letter of credit sets forth in full our undertaking, and such undertaking shall not in any way be modified, amended, amplified, or limited by reference to any document, instrument, or agreement referred to herein, except for Annexes 1, 2, and 3 hereto and the notices referred to herein; and any such reference shall not be deemed to incorporate herein by reference any document, instrument, or agreement except as otherwise provided in this paragraph 5.

6. Communications with respect to this letter of credit shall be in writing and shall be addressed to us at the address referred to in paragraph 1 above, and shall specifically refer to this letter of credit no. \_\_\_\_\_.

Very truly yours,

[LOC Issuer]

Authorized signature

**ANNEX 1**  
**TO LETTER OF CREDIT NO. \_\_\_\_\_**

Draft under Letter of Credit No. \_\_\_\_\_

[ *Month, Day, Year* ]

On [*third Business Day next succeeding date of presentation*]

Pay to Tennessee Valley Authority U.S. \$ \_\_\_\_\_ [not to exceed amount available to be drawn]  
400 West Summit Hill Drive, WT 4C  
Knoxville, TN 37902-1401

[*insert any wire instructions*]

For value received and charge to account of Letter of Credit No. \_\_\_\_\_ of \_\_\_\_\_

By: \_\_\_\_\_

Title: \_\_\_\_\_



**ANNEX 2**  
**TO LETTER OF CREDIT NO. \_\_\_\_\_**

Drawing under Letter of Credit No. \_\_\_\_\_

The undersigned, a duly authorized representative of the **Tennessee Valley Authority**, a corporate agency and instrumentality of The United States of America ("Beneficiary"), hereby certifies on behalf of Beneficiary to \_\_\_\_\_ with reference to irrevocable standby Letter of Credit No. \_\_\_\_\_ (the "Letter of Credit") issued for the account of \_\_\_\_\_, (" X "), that:

- 1) [pursuant to the \_\_\_\_\_ Agreement between Beneficiary and  X , as of the date hereof Beneficiary is entitled to draw under the Letter of Credit;---or-- [Beneficiary has received notice from the Issuing Bank pursuant to Section 3 of the Letter of Credit and, as such, as of the date hereto Beneficiary is entitled to draw under the Letter of Credit;]
- 2) by presenting this certificate and the accompanying sight draft, Beneficiary is requesting that payment in the amount of \$\_\_\_\_\_, as specified on said draft, be made under the Letter of Credit by wire transfer or deposit of funds into the account specified on said draft;
- 3) the amount specified on the sight draft accompanying this certificate does not exceed the amount to which Beneficiary is entitled to draft under said \_\_\_\_\_ Agreement.

In witness whereof, Beneficiary has caused this certificate to be duly executed and delivered by its duly authorized representative as of the date and year written below.

Date: \_\_\_\_\_

By: \_\_\_\_\_  
Title: \_\_\_\_\_

**ANNEX 3**  
**TO LETTER OF CREDIT NO. \_\_\_\_\_**

Notice of surrender of Letter of Credit No. \_\_\_\_\_

Date: \_\_\_\_\_

Attention: Letter of Credit Department

Re: Letter of Credit No. \_\_\_\_\_ issued for the account of \_\_\_\_\_ (Seller)

Ladies and Gentlemen:

We refer to your above-mentioned irrevocable standby Letter of Credit (the "Letter of Credit"). The undersigned hereby surrenders the Letter of Credit to you for cancellation as of the date hereof. No payment is demanded of you under this Letter of Credit in connection with this surrender.

Very truly yours,

\_\_\_\_\_

By: \_\_\_\_\_

Title: \_\_\_\_\_

## EXHIBIT B

### INSURANCE

A. Seller Insurance Coverages. Seller shall maintain or cause to be maintained the types of insurance coverages described in this Part A, provided that Seller shall be required to maintain the insurance coverages described in this Part A only to the extent that such coverages are available on Commercially Reasonable terms in the commercial insurance markets. All insurance coverages described herein shall be placed with Acceptable Insurance Companies. An “Acceptable Insurance Company” means an insurance company that, at the applicable time, is legally permitted to write the applicable insurance coverage and that (i) has a Credit Rating of A- or better from Standard & Poor’s at such time or (ii) has an insurance company rating of A- or better from A.M. Best at such time.

1. Workers’ Compensation Insurance. Seller shall maintain or cause to be maintained workers’ compensation insurance or a local government job injury program in compliance with Applicable Law.

2. Commercial General Liability Insurance. Seller shall maintain or cause to be maintained liability insurance in accordance with the requirements of the Tennessee Governmental Tort Liability Act as it ay be amended from time to time.

3. Automobile Liability Insurance. Seller shall maintain or cause to be maintained liability insurance for owned, non-owned and hired automobiles in accordance with the requirements of the Tennessee Governmental Tort Liability Act as it may be amended from time to time.

4. All-Risk Property Insurance. Seller shall maintain or cause to be maintained all-risk property coverage for the Project with Commercially Reasonable limits, sub-limits and deductibles.

B. Seller Insurance General Terms. To the extent available on Commercially Reasonable terms in the commercial insurance markets:

1. Evidence of Coverage. Seller shall deliver to TVA certificates or other evidence of all insurance policies maintained (or caused to be maintained) by Seller within twenty (20) days after the Execution Date and each time thereafter when there is any renewal of such insurance policies.

2. Termination of Coverage. Seller shall provide TVA prior written notice of any cancellation or non-renewal of any insurance policy required to be maintained (or caused to be maintained) by Seller pursuant to this Exhibit B.

C. Self Insurance. Notwithstanding the foregoing, Seller may self-insure to meet the minimum insurance requirements of this Exhibit B to the extent it maintains a self-insurance program, provided that Seller’s senior secured debt meets the ratings requirements applicable to a Qualified Bank and its self-insurance program meets the minimum insurance requirements of this Exhibit B. For any period of time that Seller’s senior secured debt is unrated by Standard & Poor’s or is rated at less than investment grade by Standard & Poor’s, Seller shall comply with the insurance requirements applicable to it under this Exhibit B. In the event that Seller is permitted to self-insure pursuant to this section, it shall notify TVA that it meets the requirements to self-insure and that its self-insurance program meets the minimum insurance requirements in a manner consistent with that specified in this Exhibit B.

## EXHIBIT C-1

### PROVISIONS RELATING TO THE GUIDELINES

In accordance with Section 3.4(b) of the Agreement, Seller will include the provisions set forth below (or substantially equivalent language) in the Frontend PPA:

(a) [Operator] is responsible, at its sole cost and expense, for complying with the following obligations of [Seller] under the TVA's Flexibility Program Guidelines that are in effect as of the effective date of this Agreement ("Guidelines"), a copy of which is attached as Exhibit C-2 to this Agreement:

(i) Participating in any "Facilities Study", "System Impact Study", "Transmission Screen" and providing any "Flexibility Device Kit," as each such term is defined in the Guidelines;

(ii) Complying with all "Interconnection Requirements", "Commissioning Requirements", "Modeling Requirements", and "TVA Operating Procedures" and related requirements, as such terms and requirements are specified in the Guidelines; provided, however, that the Interconnection Agreement and TVA's published interconnection procedures shall control all matters relating to the interconnection of the Project to the TVA Electric System;

(iii) Installing any protection equipment and taking any actions determined by TVA to be necessary to address any adverse impacts on TVA's transmission system that will be caused by the installation or operation of the Project, and reimbursing TVA for any equipment costs incurred by TVA in connection with addressing these transmission system impacts, all in accordance with TVA's published interconnection procedures and the Interconnection Agreement;

(iv) Reimbursing TVA for the costs of procuring and installing any TVA-owned meters that are required for the deployment and operation of the Project in accordance with TVA's "Metering Requirements" as such term is defined in the Guidelines;

(v) Providing such metering and communication devices for the Project as may be required by TVA to ensure its operational reliability under its operating guidelines, to provide TVA with unrestricted remote access to metering data at all times, and physical access to metering facilities for the purpose of confirming remotely accessed data, all in accordance with TVA's published interconnection procedures and the Interconnection Agreement;

(vi) Complying with TVA interconnection procedures and standards in effect at the time of interconnection; and

(vii) Executing any necessary agreements and other necessary documentation as TVA may require pursuant to the Guidelines relating to the metering, operation and maintenance of the Project.

Seller shall be responsible for fully discharging each of these obligations on behalf of Operator .

(b) Notwithstanding any other provision in this Agreement to the contrary, in the event of a conflict between the terms of this Agreement and the foregoing requirements under the Guidelines, the Guidelines will control as necessary to resolve the conflict, except (i) where the Guidelines incorporate by reference the Power Supply Expanded Flexibility Agreement or similar agreement between TVA and Seller, and in which case this Agreement shall control over the Guidelines; and (ii) where such conflict relates to the interconnection or parallel operation of the Project, in which case TVA's published interconnection procedures and the Interconnection Agreement shall control.

EXHIBIT C-2

TVA'S FLEXIBILITY PROGRAM GUIDELINES

## EXHIBIT C-3

### LEGALLY REQUIRED CLAUSES

The Parties shall comply with all Applicable Law. To the extent required by Applicable Law, the following clauses shall apply to the Parties' performance of the Agreement to which this Exhibit C is attached. References in this Exhibit C to "contract" refer to the Agreement to which Exhibit C is attached.

#### AFFIRMATIVE ACTION AND EQUAL OPPORTUNITY

To the extent applicable, this contract incorporates by reference the Affirmative Action for Disabled Veterans and Veterans of the Vietnam-Era clause, 41 C.F.R. § 60-250.4; the Affirmative Action for Handicapped Workers clause, 41 C.F.R. § 60-741.4; the Equal Opportunity clause, 41 C.F.R. § 60-1.4; and the Discrimination on the Basis of Age clause, 18 C.F.R. § 1316.6; and all amendments thereto and all applicable regulations, rules, and orders issued thereunder. Seller complies with applicable regulatory requirements, including information reports and affirmative action programs.

#### BYRD RIDER

Lobbying. This contract is subject to the requirements of Public Law No. 101-121 (codified at 31 U.S.C. § 1352), which prohibits certain lobbying activities and requires disclosure of certain others, and to TVA's implementing regulations published at 55 Fed. Reg. 6736 (codified at 18 C.F.R. § 1315).

##### A. Prohibition, Certification, and Disclosure

- (1) Appropriated Funds. Section 319 of Public Law No. 101-121 provides that none of the funds appropriated by any act of Congress may be expended by the recipient of a Federal contract, grant, loan, or cooperative agreement to pay any person for influencing or attempting to influence an officer or employee of any agency, a member of Congress, an officer or employee of Congress, or an employee of a member of Congress in connection with: (a) the awarding of any Federal contract; (b) the making of any Federal grant; (c) the making of any Federal loan; (d) the entering into of any cooperative agreement; or (e) the extension, continuation, renewal, amendment, or modification of any Federal contract, grant, loan, or cooperative agreement.
- (2) Certification. Seller, by signing this contract, certifies in accordance with the "Certification for Contracts, Grants, Loans, and Cooperative Agreements," set forth below ("Certification"), that it has not violated the foregoing prohibition.
- (3) Other Than Appropriated Funds. Except as provided in subsection D, below, if Seller has paid or will pay any funds other than Federal appropriated funds to any person for influencing or attempting to influence an officer or employee of any agency, a member of Congress, an officer or employee of Congress, or an employee of a member of Congress in connection with this contract, Seller shall complete and submit to TVA Standard Form-LLL, "Disclosure of Lobbying Activities," in accordance with its instructions. (Copies of Standard Form-LLL may be obtained from the TVA representative for this contract.) The requirements of this subsection A(3) shall not apply to payments of reasonable compensation to regularly employed officers or employees. The term "regularly employed," with respect to an officer or employee of a person requesting or receiving a contract, means an officer or employee who is employed by such person for at least 130 working days within one year immediately

preceding the date of the submission that initiates TVA's consideration of such person for receipt of such contract.

- B. Updating. At the end of each calendar quarter in which there occurs any event that materially affects the accuracy of the information contained in the Certification or, if applicable, Standard Form-LLL, Seller shall file with TVA an initial or new Standard Form-LLL with such new information or modifications as are necessary to correct any inaccuracies in the information originally declared and certified.
- C. Subcontractors. Seller shall include or cause to be included the form of the Certification in any subcontract exceeding \$100,000 at any tier. Seller shall promptly file with TVA each Standard Form-LLL provided by a subcontractor.
- D. Exceptions. The prohibition described in subsection A(1) above and the disclosure requirements in subsection A(3) do not apply in the case of (1) a payment of reasonable compensation made to an officer or employee of Seller to the extent that the payment is for agency and legislative liaison activities not directly related to a Federal action referred to in subsection A; or (2) any reasonable payment to a person, or any payment or reasonable compensation to an officer or employee of Seller, if the payment is for professional or technical services rendered directly in the preparation or negotiation of this Agreement.
- E. Definitions. Terms not defined herein shall have the meanings ascribed to them in Public Law No. 101-121 and TVA's implementing regulations.
- F. Penalties. (1) Any person who makes an expenditure prohibited by Public Law No. 101-121 shall be subject to a civil penalty of not less than \$10,000 and not more than \$100,000 for each such expenditure; and (2) any person who fails to file or amend a certification required under subsection A(2) above or a disclosure required to be filed or amended under subsection A(3) above shall be subject to a civil penalty of not less than \$10,000 and not more than \$100,000 and to such other remedies as may apply for each such failure.

Certification for Contracts, Grants,  
Loans, and Cooperative Agreements

The undersigned certifies, to the best of his or her knowledge and belief that:

- (1) No Federal appropriated funds have been paid or will be paid by or on behalf of the undersigned to any person for influencing or attempting to influence an officer or employee of any agency, a member of Congress, an officer or employee of Congress, or an employee of a member of Congress in connection with the awarding of any Federal contract, the making of any Federal grant, the making of any Federal loan, the entering into of any cooperative agreement, and the extension, continuation, renewal, amendment, or modification of any Federal contract, grant, loan, or cooperative agreement.
- (2) If any funds other than Federal appropriated funds have been paid or will be paid to any person for influencing or attempting to influence an officer or employee of any agency, a member of Congress, an officer or employee of Congress, or an employee of a member of Congress in connection with this Federal contract, grant, loan, or cooperative agreement, the undersigned shall complete and submit Standard Form-LLL, "Disclosure of Lobbying Activities," in accordance with its instructions.

- (3) The undersigned shall require that the language of this certification be included in the award documents for all subawards at all tiers (including subcontracts, subgrants, and contracts under grants, loans, and cooperative agreements) and that all subrecipients shall certify and disclose accordingly.

This certification is a material representation of fact upon which reliance was placed when this transaction was made or entered into. Submission of this certification is a prerequisite for making or entering into this transaction imposed by 31 U.S.C. 1352. Any person who fails to file the required certification shall be subject to a civil penalty of not less than \$10,000 and not more than \$100,000 for each such failure.



## EXHIBIT D-1

### PROJECT DESCRIPTION

The Project comprises the Biomass Asset and associated equipment and facilities, together known as COLUMBUS CELLULOSE FIBERS COGENERATION FACILITY, located in LOWNDES COUNTY, MISSISSIPPI, including the real property, fixtures, and land rights associated with the facility. The Project is located at Latitude N33.35879 degrees, Longitude W88.45996 degrees, in Section 7, Township 17 North Range 18 East, Lowndes County, Mississippi.

The Biomass Asset is a 45 MW generation facility that uses the heat generated by Biomass Co-firing or the combustion of Qualified Biomass to generate electricity.

**Qualified Biomass** means a solid, liquid, or gaseous form of Renewable Biomass that is produced from the following fuels in a manner that complies with all applicable Laws and Regulations:

- a. All wood waste including “black liquor” from pulp and paper processing, mill residues, industrial waste wood, and wasted wood from woodworking or wood processing, and woody biomass has hog fuel or bark, so long as the wood is not chemically treated or coated;
- b. All agricultural crops or waste;
- c. All animal and other organic waste;
- d. All energy crops; and
- e. Landfill gas and wastewater methane.

**Biomass Co-firing** of eligible forms of Qualified Biomass with non-renewable fuel is permitted if all of the following conditions are met:

- a. The Qualified Biomass is separately metered, and Operator verifies, in a method approved by TVA, that the Qualified Biomass portion is converted to Energy Output;
- b. At least 50% of the heat input is from Qualified Biomass;
- c. The Biomass Asset is in compliance with all Applicable Laws regarding emissions; and
- d. emissions from the non-Qualified Biomass portion do not exceed TVA’s average annual emissions rates as reported in eGrid (<http://www.epa.gov/cleanenergy-resources/egrid/index.html>).

The Biomass Asset at all times will generate and deliver electric power and energy exclusively from the combustion of Qualified Biomass or from Biomass Co-firing. Unless approved in advance by TVA in writing, the Biomass Asset will not generate or deliver electric power or energy by means of non-biomass combustion generation technologies; provided, however, that Seller recognizes and affirms that Operator may generate electric power and energy from the same Biomass Assets for its own station load, but will apportion only Qualified Biomass fuels as defined in this Exhibit D-1 to Seller’s generation.

The Project will be interconnected at the “Delivery Point,” which is WEYERHAEUSER 161-kVA SWITCHYARD and the settlement point will be the TVA LOWNDES TRANSMISSION SYSTEM.

### Contract Output and Term Schedule

The maximum Contract Output under this Agreement will be as set forth in the tabulation below.

Date	Contract Output (MW)
Effective Date - 1/30/2025	32.674
1/31/2025 - 12/31/2026	24.674
12/1/2026 – 6/29/2028	16.674

TVA may, in its sole discretion, adjust the tabulation set forth above in the event Seller enters into additional projects or initial delivery dates for projects change under TVA's Generation Flexibility Program.

In the event Seller deploys additional Energy Resources or the initial delivery dates of Energy Resources change under TVA's Generation Flexibility Program, Seller may request an adjustment to the tabulation set forth above by submitting to TVA, at least 45 days prior to the desired adjustment date, a request detailing Seller's desired adjustments to the tabulation set forth above. TVA will review the request, and, in its reasonable discretion, approve or deny said request. If TVA denies Seller's request, it will provide Seller a response detailing its reasoning. Nothing in this section authorizes Seller to violate any terms under the Enhanced Flexibility Agreement or the Enhanced Flexibility Guidelines attached thereto.

Whether the Project satisfies the Contract Output requirement will be determined by measuring the maximum instantaneous AC power output of the Project, using the Metering Equipment, at the high side of the Delivery Point transformer, net of any station service and transmission and distribution losses.

# Power Supply Expanded Flexibility Program Guidelines

Tennessee Valley Authority (TVA)

---

## Contents

General Terms and Conditions.....	1
Energy Resources .....	2
Crediting and Pricing Structure .....	5
Valley Partner Hosted Option Guidelines.....	6
TVA Interconnected Option Guidelines.....	8
End-Use Customer Hosted Option Guidelines.....	10
Required Forms.....	13

IMPLEMENTATION OF A POWER SUPPLY EXPANDED FLEXIBILITY OPTION MAY HAVE IMPACTS ON EXISTING PRODUCTS OR PROGRAMS FROM TVA THAT ARE BASED ON A VALLEY PARTNER'S DEMAND AND ENERGY TAKINGS.

ANY ACTIONS TAKEN BY A PARTY IN RELIANCE ON THE TERMS SET FORTH IN THESE PROGRAM GUIDELINES, PROGRAM FORMS, OR ON STATEMENTS MADE DURING NEGOTIATIONS OR DISCUSSIONS PURSUANT TO THE SUBJECT MATTER HEREIN SHALL BE AT SUCH PARTY'S OWN RISK. UNTIL DEFINITIVE AGREEMENT(S) HAVE BEEN EXECUTED BETWEEN OR AMONG THE PARTIES, NO PARTY SHALL HAVE ANY LEGAL OBLIGATIONS, EXPRESS OR IMPLIED, OR ARISING IN ANY OTHER MANNER UNDER THESE PROGRAM GUIDELINES, PROGRAM FORMS, OR IN THE COURSE OF NEGOTIATION OR DISCUSSIONS. SUCH DEFINITIVE AGREEMENT(S) ARE THE ONLY DOCUMENT(S) THAT WOULD CREATE A BINDING LEGAL OBLIGATION BETWEEN OR AMONG THE PARTIES WITH RESPECT TO THE SUBJECT MATTER HEREIN.

---

## General Terms and Conditions

### Program Guidelines

- These Program Guidelines are intended to provide Valley Partners with a framework of various project options by which each Valley Partner may find more opportunity to utilize their Enhanced Flexibility Volume through the Deployment of Energy Resources using the following options.
- Capitalized Terms used in these Program Guidelines have the same meaning as in the Power Supply Expanded Flexibility Agreement (“Agreement”). In the event of any conflict between the body of the Agreement and these Program Guidelines, the Agreement controls.
- TVA may amend these Program Guidelines at any time, in part or in whole, by posting such amendments under “Flexibility Option - General Information” on the Valley Connect Programs page at <https://valleyconnect.tva.gov/resources/programs>, or such successor website as TVA may designate from time to time. Such amendments will be effective upon 30 days’ written notice in accordance with the Agreement and will not apply to any Energy Resource documented by an Initiation Notice Form (“INF”) approved by TVA in accordance with these Program Guidelines prior to the effective date of such amendments. This paragraph does not apply to any adjustments made to the price per kWh stated in the Crediting and Pricing Structure section of these Program Guidelines.
- Terms and conditions in these Program Guidelines are in addition to and made a part of the Agreement.

### Authorization and Participation

- The Agreement is available only to local power companies that have an effective Long-Term Agreement (“LTA”) with TVA (“Valley Partners”) and will be an amendment to the Valley Partner’s wholesale power contract (“Power Contract”).
- Implementation of Expanded Flexibility will be in accordance with the TVA Board Approval dated August 31, 2022.

---

## Energy Resources

### Eligibility

- No Energy Resource may be Deployed until it has been approved by TVA in accordance with the Agreement and these Program Guidelines.
- No expansion of the capacity of an Energy Resource may occur without the prior written approval of TVA.
- TVA may reject any Energy Resource, in whole or in part, if, in TVA's sole discretion, it deems that the Energy Resource poses a potential safety risk or adverse impact to a transmission or distribution system.

### Requirements

- TVA, in its sole discretion, at any time during the approval process or while the Energy Resource is Deployed, may require, at a Valley Partner's cost, one or more of the following for an Energy Resource facility in order to determine any adverse impacts to TVA's transmission system, what transmission equipment and/or network upgrades are required, what Excess Generation TVA may be able to take onto its transmission system, and other factors and requirements for safe operation and Deployment of an Energy Resource:
  - "Facilities Study" means a formal scoping process by TVA using other studies (including the System Impact Study) and information to produce the necessary project drawings, detailed cost estimates, and work schedule for the Deployment of a potential Energy Resource facility.
  - "Flexibility Device Kit" means TVA's preferred communication link for acquiring generation data from Energy Resources (if other existing communication links are not available), which includes a cell router, GPS clock, AC-DC converter, and TVA implementation support.
  - "System Impact Study" means an engineering study completed by TVA to identify the impact and any scope of work necessary for the safety and reliability of TVA's transmission system and for the interconnection of an Energy Resource to TVA's transmission system or Valley Partner's distribution system.
  - "Transmission Screen" means a study performed by TVA to determine the appropriate load sizing for a potential Energy Resource at a given delivery point, including but not limited to metering, protection, and visibility requirements.
- "Interconnection Requirements" means the latest version of TVA's Energy Supply Facility Interconnection Requirements and Procedures, with which all Energy Resources must comply, and as applicable the North American Electric Reliability Corporation (NERC) registration requirements.
- "Commissioning Requirements" means the latest version of TVA's Commissioning Checklist and Guidelines. An Energy Resource at or above 25 MVA will be subject to the full Commissioning Requirements and, in TVA's sole discretion, an Energy Resource with Deployment below 25 MVA may require full or partial compliance with the Commissioning Requirements.
- "Modeling Requirements" means the latest version of TVA's Modeling Requirements for Synchronous Generators and Inverter-Based Resources. An Energy Resource at or above 25 MVA will be subject to the full Modeling Requirements and, in TVA's sole discretion, an Energy Resource with Deployment below 25 MVA may require full or partial compliance with the Modeling Requirements.

- 
- An Energy Resource at or above 25 MVA must comply with TVA's Operating Procedures and deliver to TVA forecasting information, including but not limited to, a daily projected output schedule and other forecasting information TVA may reasonably require.
  - If TVA identifies, at any time during the approval process or while the Energy Resource is Deployed, any adverse impacts on TVA's transmission system that will be caused by a Valley Partner's planned Energy Resource(s), TVA will notify the Valley Partner of the protection equipment and actions necessary to remediate such adverse impact. The Valley Partner will coordinate with TVA for the installation of any such necessary equipment and actions and reimburse TVA for TVA's equipment costs.
  - In TVA's sole discretion, TVA-owned meter(s) may be required for the Deployment and continued operation of an Energy Resource. The Valley Partner must reimburse TVA for TVA's costs in procuring and installing such meter(s) in accordance with the Metering Requirements.
  - Valley Partners are responsible for metering and communication devices for its Energy Resources to ensure TVA operational reliability in accordance with the Program Guidelines, and are required to provide TVA with unrestricted remote access to metering data at all times, and physical access to the metering facilities for the purpose of confirming remotely accessed data, during such time periods that TVA specifies, and in cooperation with the Host Valley Partner's operating representatives.

## Technology Factors

- Technology Factors will be assigned to Energy Resources as follows:
  - 0.2 - for solar-based power generating Energy Resources with an alternating current nameplate rating of less than 250 kW and in compliance with the End-Use Customer Hosted Option Guidelines;
  - 0.4 - for solar-based power generating Energy Resources not included in the End-Use Customer Hosted Option;
  - 1.0 for Energy Resources that are not solar based; and
  - as calculated, in TVA's sole discretion, for other Energy Resources not included in the categories above.
- Technology Factor examples:
  - A solar-based power generating Energy Resource in compliance with the End-Use Customer Hosted Option guidelines that has an alternating current nameplate rating of 250 kW; equals  $250 \text{ kW} \times 0.2 = 50 \text{ kW}$  of Enhanced Flexibility Volume.
  - A solar-based power generating Energy Resource has an alternating current nameplate rating of 10 MW; equals  $10 \text{ MW} \times 0.4 = 4 \text{ MW}$  of Enhanced Flexibility Volume.
  - A combined heat and power facility has a nameplate rating of 5 MW; equals  $5 \text{ MW} \times 1.0 = 5 \text{ MW}$  of Enhanced Flexibility Volume.
- In accordance with the Agreement, a Legacy Energy Resource will retain the Technology Factor assigned to it at the time its INF was approved, so long as the Legacy Energy Resource continues to be operated in accordance with the terms and conditions of the INF at the time of its approval.

---

## Energy Resource Aggregation

- Valley Partners may “aggregate” all or a portion of Enhanced Flexibility Volumes into a single Aggregated Energy Resource, so long as:
  - the total capacity Deployed by the Energy Resource does not exceed the aggregated total Enhanced Flexibility Volume allocated and contributed to the Energy Resource from all Subscribed Valley Partners, in accordance with the Agreement and these Program Guidelines; and
  - each individual Valley Partner’s Enhanced Flexibility Volume does not exceed the Enhanced Flexibility Volume Cap as allowed, calculated, and assigned by TVA to each individual distributor.



---

## Crediting and Pricing Structure

Energy Resources will either (a) displace demand and energy usage that TVA would have otherwise generated, delivered, and charged on Distributor's monthly wholesale power invoice or (b) be treated in accordance with a wholesale crediting mechanism in accordance with the following:

### Flexibility Option Power Purchase Agreement ("FOPPA"):

- For solar Energy Resources directly interconnected to TVA's transmission system, TVA will purchase exclusive rights and title to 100% of the energy output from the Valley Partner who has a PPA with the developer or owner of the Energy Resource.
- For all energy delivered to and purchased by TVA at the delivery point, TVA will pay the Valley Partner \$55.55 per MWh plus the Standard Service Total Monthly Fuel Cost ("TMFC") rates for the billing month.
- Specific payment terms, metering requirements, and contract price provisions are defined in the FOPPA.
- For any conflict between these Program Guidelines and the FOPPA, the FOPPA governs.

### Excess Option Power Purchase Agreement ("EOPPA"):

- For solar Energy Resources directly interconnected to a Valley Partner's distribution system; the Valley Partner will offset demand and energy usage otherwise generated, delivered, and charged by TVA.
- For any solar generation in excess of load at a delivery point that causes energy to flow onto the TVA transmission system at any interval, TVA will purchase exclusive rights and title to any such energy from the Valley Partner who has a PPA with the developer or owner of the Energy Resource.
- For all energy delivered to and purchased by TVA at the delivery point, TVA will pay the Valley Partner \$34.40 per MWh plus the Standard Service Total Monthly Fuel Cost ("TMFC") rates for the billing month.
- Specific payment terms, metering requirements, and contract price provisions are defined in the EOPPA.
- For any conflict between these Program Guidelines and the EOPPA, the EOPPA governs.

### Other

- The provisions in these Program Guidelines applicable to the FOPPA and EOPPA apply to Energy Resources for which a Valley Partner has executed a PPA.
- The FOPPA and EOPPA rates apply exclusively to solar-based power generating Energy Resources and may be adjusted by TVA consistent with changes, increase or decrease, to Standard Service Wholesale rate changes and adjustments.
- TVA will notify Valley Partners of any such adjustment, and the effective date of the adjustment, either (1) in accordance with section 10.5 of the Agreement, or (2) in the fuel cost adjustment Statement of Amounts.
- These Program Guidelines do not limit TVA's right to change or replace its formula to determine price per kWh.
- For non-solar-based Energy Resources, upon request from a Valley Partner, TVA will calculate a separate technology-specific rate.

---

## Valley Partner Hosted Option Guidelines

These Valley Partner Hosted Option Guidelines establish the processes and procedures to be followed by Valley Partners and TVA for the implementation of a Valley Partner Hosted Energy Resource (“VP Project”). A VP Project is an Energy Resource that is directly connected to a Valley Partner’s distribution system for Deployment on that Valley Partner’s system, may include Excess Generation that flows onto TVA’s transmission system that TVA purchases from Valley Partner, and/or may be an Aggregated Energy Resource. Valley Partners should read and understand all the terms and conditions set forth in the Agreement and these Program Guidelines.

### Participation Requirements

**Valley Partner(s) must**, in accordance with the Agreement, these Program Guidelines, and in any forms or instructions, as they may be requested, required, and updated from time to time by TVA:

- submit a completed INF describing participation in the Valley Partner Hosted Option;
- maintain responsibility for, and all costs associated with, the planning (including environmental reviews), development, Deployment, continued operation, and ceasing operation of the VP Project;
- comply with all standards, guidelines, reporting and data obligations;
- as applicable, execute a PPA with the project developer or owner for the Deployment and operation of the VP Project and continually maintain such effective agreement while the VP Project is Deployed;
- take title to all Environmental Attributes, capacity-equivalent benefits, and other project attributes associated with the Valley Partner’s Enhanced Flexibility Volume contribution or allocation to the VP Project;
- manage, sell, transfer, and retire the RECs generated by the VP Project consistent with the Agreement, and provide attestation to such;
- maintain responsibility for the negotiation, preparation, execution, completion, implementation, and ongoing administration of the PPA and all other agreements associated with the planning, development, Deployment, continued operation, and ceasing operation of the VP Project;
- as applicable, in TVA’s sole discretion, enter into any other agreements (e.g., Interconnection Agreement and/or Parallel Operation Agreement) required for the initial and continued safe Deployment of an Energy Resource;
- implement curtailment requirements; and
- as applicable, enter into an EOPPA with TVA for any Excess Generation that flows from the VP Project onto the TVA transmission system.

### Aggregated Energy Resource Requirements

#### Host Valley Partner:

- “Host Valley Partner” means the Valley Partner in whose service territory a VP Project is located and directly connected to that Valley Partner’s distribution system. The Host Valley Partner may also be a Subscribed Valley Partner for the VP Project.

- 
- The Host Valley Partner must take physical delivery of and title to all energy output from the VP Project, along with taking title to all Environmental Attributes and other project attributes;
  - The Host Valley Partner, as applicable, must enter into and administer a mutually agreeable contractual agreement with each Subscribed Valley Partner outlining the allocation of equivalent benefits, sale or transfer of Environmental Attributes and/or RECs, and any other details related to the planning, implementation, Deployment, continued operation, and ceasing operation of the VP Project;
  - The Host Valley Partner must certify on the INF, subject to TVA approval, the manner in which all financial and environmental benefits will be allocated to Subscribed Valley Partners;
  - The Host Valley Partner is responsible for Energy Resource Administration and may receive a financial or other benefit (“Host Fee”) from other Subscribed Valley Partners as compensation for the time and cost it incurs to complete its Host Valley Partner functions associated with Energy Resource Administration of the VP Project. The Host Valley Partner and all other Subscribed Valley Partners must mutually agree in writing to the Host Fee.
    - Energy Resource Administration includes but is not limited to: the planning, development, Deployment, continued management and operation, and ceasing operations of the VP Project; PPA management; REC management and retirement; administration of allocating the financial and environmental benefits to all Subscribed Valley Partners; metering, transmission, and billing obligations; and any other administrative and operational activities associated with the VP Project.
  - **Enhanced Flexibility Volume Considerations:**
    - A Valley Partner that has reached its Enhanced Flexibility Volume Cap may still act as a Host Valley Partner for a VP Project in accordance with the following:
      - the Host Valley Partner and all Subscribed Valley Partners mutually agree in writing to a Host Fee as described in these Program Guidelines;
      - the Host Valley Partner does not receive any benefits that exceed the Host Fee.
    - A Valley Partner that has remaining Enhanced Flexibility Volume may act as Host Valley Partner for a VP Project with or without receiving a capacity allocation or equivalent benefit from the VP Project and must indicate and certify such election on the INF.

---

## TVA Interconnected Option Guidelines

These additional TVA Interconnected Option Guidelines establish the processes and procedures to be followed by a Valley Partner and TVA for the implementation of a TVA Interconnected Energy Resource (“Interconnected Project”). The Valley Partner should read and understand all the terms and conditions set forth in the Agreement and these Program Guidelines.

### Participation Requirements

- **The Valley Partner(s) must**, in accordance with the Agreement, these Program Guidelines, and in any forms or instructions, as they may be requested, required, and updated from time to time by TVA:
  - submit a completed INF describing participation in the TVA Interconnected Option;
  - comply with all standards, guidelines, reporting and data obligations, and other requirements and responsibilities;
  - follow the TVA interconnection procedures and standards in effect at the time of interconnection; and
  - execute a separate PPA with TVA, substantially in the form of the FOPPA (an example of which may be provided by TVA at the request of a Valley Partner), for TVA’s purchase and title to all energy output delivered from the Interconnected Project onto the TVA transmission system, resulting in TVA taking physical delivery of all energy output delivered from the Interconnected Project;
  - maintain responsibility for, and all costs associated with, the planning, development, Deployment, continued operation, and ceasing operation of the Interconnection Project, including the negotiation, preparation, execution, implementation, and ongoing administration of a PPA with project developer or owner, and all other agreements associated with the planning, development, Deployment, continued operation, and ceasing operation of the Interconnected Project;
  - take all right, title, and interest in and to energy output, Environmental Attributes, and other project attributes generated under a PPA entered into between the Valley Partner and the project developer or owner;
    - A PPA between the Valley Partner and project developer or owner must:
      - (1) be entered into between the Valley Partner and project developer or owner;
      - (2) confer to the Valley Partner any and all right, title, and interest in and to energy output, Environmental Attributes, and other project attributes generated under a PPA;
      - (3) require Continuous Reactive Power Support (“CRPS”): CRPS is a local grid voltage control service provided by the Interconnected Project’s solar inverters during periods when the Interconnected Project is not generating power but is able to receive power from TVA;
      - (4) ensure that no construction activities are initiated at the Interconnected Project site, whether by the Valley Partner, the project developer or owner, or any third party, until TVA has provided written notice to the Valley Partner that TVA’s environmental reviews have been satisfactorily completed;
      - (5) allow for TVA to require the project developer or owner to effect a curtailment or disconnection of the Interconnected Project, in accordance with the Interconnection Agreement with TVA;

- 
- (6) at the Valley Partner's expense, ensure that by no later than the date the project generates and delivers power to the TVA transmission system, an automatic generation control (AGC) system for the Interconnected Project is installed in accordance with TVA's specifications and direction;
  - (7) require the project developer or owner adhere to the then current Program Guidelines in effect at the time the PPA was entered into to the extent applicable, and state that in the event of a conflict between the PPA and such Program Guidelines, the Program Guidelines controls;
  - (8) require, in TVA's sole discretion, the execution of any necessary agreements (e.g., Interconnection Agreement) and other necessary documentation between the project developer or owner and TVA or the Valley Partner, as applicable to address metering, operation, maintenance, and other related matters; and
  - (9) include other such terms and conditions as TVA may reasonably require.
- **TVA will** execute a separate agreement with the Valley Partner, substantially in the form of a FOPPA (an example of which may be provided by TVA at the request of a Valley Partner), for TVA's purchase and title to all energy output delivered to the TVA transmission system resulting in TVA taking physical delivery of the energy output from the Interconnected Project.

## Process Requirements

- **PPA Administration:**
  - Administration of a PPA will be the responsibility of the Valley Partner and must be in accordance with these Program Guidelines and the requirements of the PPA between TVA and the Valley Partner. This may include, but is not limited to, negotiations, exercising contractual rights under a PPA, milestone determinations and extensions, enforcement of remedies for non-performance, and pricing increases.
- **Aggregated Projects:**
  - More than one Valley Partner may subscribe to a TVA Interconnected Project, and may enter into a separate PPA with the project developer or owner for receiving an allocation of capacity from the Energy Resource, so long as all Subscribed Valley Partners individually enter into a PPA with TVA for TVA's purchase of and title to all energy output delivered from the Interconnected Project to the TVA transmission system. All energy output must be sold to TVA.

---

## End-Use Customer Option Guidelines

These additional End-Use Customer Hosted Guidelines establish the processes and procedures to be followed by a Valley Partner and TVA for the implementation of the End-Use Customer Hosted Option (“EUC Option” or “EUC Program”). The Valley Partner should read and understand all the terms and conditions set forth in the Agreement and these Program Guidelines.

A Valley Partner may implement an EUC Program only within its service territory for the solar installations of its eligible Standard Service electric system customers, and it will have the responsibilities of a Host Valley Partner.

A Valley Partner’s receipt and purchase of electric energy from such solar installations will be counted as capacity towards the Valley Partner’s Enhanced Flexibility Volume Cap, as allowed and calculated by TVA, using the applicable Technology Factor.

### Defined Terms

- “Participant” means any potentially eligible Standard Service electric system customer located and served in a Valley Partner’s service territory that elects to participate in such Valley Partner’s EUC Program.
- “Metering Installation” means meters and related facilities used to determine the amounts of electric energy flowing onto the Valley Partner’s distribution system from solar installations. TVA assumes no responsibility for the adequacy or functionality of any Metering Installation. In addition, the Metering Installation must meet the following requirements:
  - adhere to TVA’s reporting requirements and TVA’s Commercial Energy Solutions Net Metering Policy, as it may be updated from time to time by TVA;
  - conform to applicable industry standards; and
  - be for Valley Partner’s exclusive use and control unless otherwise agreed to in writing by the Participant and Valley Partner.
- “Site” means a Participant’s eligible residential, commercial, or industrial real estate and associated personal property to which the solar installation is connected. In addition, the Site must meet and maintain the following requirements:
  - The property must be located in the service territory of, and receive its retail electricity distribution services from, the Valley Partner at the location of the solar installation;
  - The primary purpose of the solar installation must be to serve the load at Participant’s premises, not primarily for energy generation sales. For example, participant may not be an entity whose main business purpose is energy generation and sales;
  - The solar installation must be located on the same premises of Participant, where the Participant’s own electrical load is located;
  - A maximum of 250 kW per Standard Service customer of Valley Partner is permitted;
  - electric energy delivered to and purchased by the Valley Partner does not exceed more than 100% of the Participant’s annual electrical usage (the aggregate of all billing meters on Participant’s contiguous property at the Site); and

- 
- Participant and the solar installation must meet the requirements set forth herein.

## Participation Requirements

- The Valley Partner is responsible for EUC program planning, development, enrollment, reporting, and administration consistent with the Agreement and these Program Guidelines. As a condition of the Valley Partner offering an EUC program, the Valley Partner must also agree to administer and manage DPP in its service area.
- The Valley Partner must:
  - submit the Expanded Flexibility End-Use Customer Program Approval Form for TVA's approval of its EUC Program;
  - submit monthly and annual reports as required by the Agreement and these Program Guidelines, and any further information reasonably requested by TVA that, in TVA's sole discretion, is needed to approve and regulate the potential EUC Program;
  - assume and maintain responsibility for certain retail facing administration obligations for current and future Dispersed Power Production (DPP) Program participants;
  - at Participant's expense, in Valley Partner's sole discretion, provide and install Metering Installation necessary to measure electrical output from the solar installation;
  - at Participant's expense, test, calibrate, operate, maintain, and, if necessary, replace the meter(s) in the Metering Installation;
  - at no cost to TVA, enter into a separate Interconnection Agreement with Participant to provide (1) a delivery point at the Site for electric energy to flow onto the Valley Partner's distribution system, (2) the Valley Partner with monthly readings from the Metering Installation, and (3) the necessary access rights in order to perform such readings. Connection of Participant's Site to the Valley Partner's distribution system shall be subject to the Rules and Regulations of the Valley Partner;
  - properly meter and account for all electric energy the Valley Partner receives and purchases, in accordance with the Agreement and these Program Guidelines;
  - the solar installation conforms to applicable industry standards or utilizes a contractor certified through TVA's Green Connect quality contractor network for the solar installation;
  - as applicable, in TVA's sole discretion, at Valley Partner's sole expense, enter into a separate metering agreement with TVA and install necessary metering and equipment; and
  - ensure that:
    - Participant's primary purpose for participating in the EUC Program is not energy generation;
    - Participant's system is an on-site solar photovoltaic ("PV") installation or solar PV with battery storage installation ("solar installation");
    - the solar installation has an alternating current nameplate rating of 250 kW or less;

- 
- the solar installation is owned or leased by a Standard Service customer of Valley Partner, as designated by the customer's power billing account that is associated with the billing meter at the address of the on-site solar installation;
  - as applicable, at Participant's sole expense, Participant receives the local building code official's inspection and certification of the solar installation and Metering Installation and submits such documentation to the Valley Partner showing that the solar installation and Metering Installation is permitted, approved, and meets all electrical and mechanical qualifications; and
  - electric energy received and purchased by the Valley Partner do not exceed more than 100% of each Participant's annual electrical usage (the aggregate of all billing meters on Participant's contiguous property at the Site).
- TVA will:
    - Provide the Valley Partner with the End Use Customer Program Approval Form for submittal to TVA and for EUC Program approval;
    - Ensure the EUC Program adheres to TVA's Net Metering Standard, as amended or superseded, and TVA's Commercial Energy Solutions Net Metering Policy, as amended or superseded;
    - Transition DPP retail facing program administration to the Valley Partner. TVA and Valley Partner will collaborate to develop a change management plan for administration, billing, and other program obligations. Valley Partner will submit such change management plan to TVA.

## Pricing Structure

- TVA will determine EUC Program pricing structures consistent with the following parameters:
  - Must be a bundled energy purchase inclusive of the environmental and emission free attributes (e.g., RECs).
  - Manage and retire environmental and emission free attributes consistent with the Agreement and these Program Guidelines.
  - Purchase price must not exceed Standard Service wholesale pricing as received by the Valley Partner from TVA.



---

## Required Forms

Valley Partner must report to TVA the following information regarding Energy Resources, using the appropriate form and frequency, both of which TVA will specify.

### Initiation Notice Form

An “Initiation Notice Form” or “INF” is required during the early planning stages of Energy Resource facility development, but in all cases no later than 90 days prior to any new Energy Resource power production. The INF keeps TVA apprised of Energy Resource development within the Host Valley Partner’s service territory, expediting TVA’s affected system interconnection studies, which TVA will conduct in a timely manner (TVA must review and provide advance, written approval of any plans to modify or operate an Energy Resource that materially differs from the Host Valley Partner’s original proposal to build such Energy Resource).

### Operational Notice Form

The “Operational Notice Form” is required prior to any Energy Resource facility power production. The Operational Notice Form notifies TVA of an Energy Resource project that is capable of and ready to generate energy and provide power, consistent with the Agreement and these Program Guidelines, along with providing TVA with relevant information about such projects, including but not limited to location, type, size, inverter data, transformer data, and other metering and interconnection information.

### Monthly Reporting Form

The “Monthly Reporting Form” is required on a schedule specified by TVA, which captures the (i) Host Valley Partner’s hourly meter data for Energy Resources every month, with projects over 1 MW individually delineated, and (ii) allocates Enhanced Flexibility Volume for all Subscribed Valley Partners, if any.

### Annual Reporting Form

“Annual Reporting,” is required on a schedule specified by TVA, which includes all information TVA requires for its transmission planning and load forecasting, including but not limited to Energy Resource generation forecasts, size, and type of projects being considered in the coming year, and timing of those projects.

### End-Use Customer Program Approval Form

An “End-Use Customer Program Approval Form” or “PAF” is required during the early planning stages of the EUC Program, but in all cases no later than 90 days prior to a Valley Partner launching its EUC Program. The PAF provides programmatic details to ensure adherence to TVA’s Net Metering Standard and transition of DPP retail facing program administration to the Valley Partner.

### Additional Forms and Information

TVA, by written notice, may require additional forms and information from Valley Partners for the administration, compliance, and continued implementation of the Agreement, these Program Guidelines, and any Energy Resource.

## RESOLUTION 1502

### **A Resolution of the Knoxville Utilities Board Honoring Adrienne Simpson-Brown, who is Concluding Service as a Commissioner**

**Whereas**, Adrienne Simpson-Brown became a member of this Board in January 2018 and has now served faithfully for seven years; and

**Whereas**, Commissioner Simpson-Brown's professional accomplishments, including being the first African American female ever appointed as Chief of the United States Probation Office for the Eastern District of Tennessee, have been an inspiration and positive example for many of KUB's employees and our community; and

**Whereas**, Commissioner Simpson-Brown dedicated her time and expertise in leading KUB's Board of Commissioners as Board Chair for two years, Vice Chair for two years, and past Chair of the Board's Nominating Committee; and

**Whereas**, Commissioner Simpson-Brown helped KUB manage the unprecedented circumstances of the COVID-19 global pandemic and its impact on customers, supporting assistance programs which aided more than 18,000 customers with nearly \$13 million in relief funds; and

**Whereas**, during Commissioner Simpson-Brown's tenure, KUB established its Diversity, Equity, and Inclusion (DEI) Initiative, which continues to promote inclusivity and equal opportunity in every facet of the organization; and

**Whereas**, during her tenure as a Commissioner, the Board established a Community Advisory Panel to represent the diverse viewpoints of KUB's customers; and

**Whereas**, during her tenure, the KUB Board voted to establish KUB's Fiber Division, enabling KUB to provide high-speed, affordable internet service to customers, including those who were previously under- or unserved and to establish the ConnectED program to provide free internet service to income-eligible student households; and

**Whereas**, Commissioner Simpson-Brown has supported KUB's lower-income assistance initiatives, including weatherization for more than 2,900 homes since 2015; and

**Whereas**, during Commissioner Simpson-Brown's tenure, KUB redefined its core values in a new Blueprint outlining our dedication to our customers, our community, our co-workers, and our culture; and

**Whereas**, Commissioner Simpson-Brown has supported continuation of utility system infrastructure investment through KUB's Century II program to ensure essential services are safely and reliably delivered to KUB customers; and

**Whereas**, during Commissioner Simpson-Brown’s tenure, KUB has made significant progress in its operations, its customer focus, its environmental stewardship, and its community impact, winning numerous awards and recognitions; and

**Whereas**, Commissioner Simpson-Brown’s engagement in the community extends beyond her tenure on the KUB Board and is reflected through her long-standing service to the Knoxville Alumnae Chapter of Delta Sigma Theta Sorority and volunteer work as a youth mentor; and

**Whereas**, Commissioner Simpson-Brown is admired for being a quiet yet strong leader who listens intently, chooses her words thoughtfully, and makes care-driven decisions; and

**Whereas**, throughout Commissioner Simpson-Brown’s service on KUB’s Board she has accomplished what she shared years ago as her aspiration for her service: “to be part of a legacy of making decisions that improve the lives of our neighbors.”

**Now, Therefore, Be It Hereby Resolved by the Board of Commissioners of the Knoxville Utilities Board:**

**Section 1.** That this Board hereby gratefully acknowledges and commends Adrienne Simpson-Brown for her dedicated service to KUB, its employees, customers, and our community.

**Section 2.** That this Board recognizes Commissioner Simpson-Brown’s meaningful and effective service and genuinely regrets that her time on the KUB Board of Commissioners has concluded.

**Section 3.** That this Resolution shall take effect from and after its passage and that a copy shall be provided to Commissioner Simpson-Brown.

Claudia Caballero/s  
Claudia Caballero, Commissioner

Ron Feinbaum/s  
Ron Feinbaum, Commissioner

Cynthia Gibson/s  
Cynthia Gibson, Commissioner

Kathy Hamilton/s  
Kathy Hamilton, Commissioner

Celeste Herbert/s  
Celeste Herbert, Commissioner

Craig Pickett/s  
Dr. Craig Pickett, Jr, Commissioner

APPROVED ON 1<sup>st</sup>  
& FINAL READING: 12-19-24  
EFFECTIVE DATE: 12-19-24  
MINUTE BOOK 49 PAGE 13368-13369